

gorenje
Life Simplified



HOUSEHOLD APPLIANCES

2019/2020

www.vosoughishop.com



QUALITY AND TRADITION

Gorenje has been producing high-quality home appliances for over 60 years. It is committed to development of own technologies and to continuous improvement of its production processes. Drawing on Slovenian tradition and European values, Gorenje remains among the leading home appliance manufacturers in Europe. We are proud of every product that leaves our factories as we are aware that it was produced and tested to meet the stringent European environment protection standards.





COOKING

Freestanding cookers
Pantry kitchens
Built-in ovens
Steam ovens
Coffee machines
Warming drawers
Built-in microwave ovens

04



HOBS

50



HOODS

78



COOLING

Built-in refrigerators and fridge freezers
Freestanding refrigerators and fridge freezers
Upright freezers
Chest freezers
Side by Side fridge freezers

96



DISHWASHING

Integrated dishwashers
Built-in dishwashers
Freestanding dishwashers

136



WASHING & DRYING

Washing machines
Tumble dryers

146



PRODUCT INFORMATION

Technical drawings

168





WE MAKE IT SIMPLIFIED. YOU MAKE IT PERFECT.

Freestanding Cookers

Ready to introduce some delicious moments to your kitchen? With the **new Gorenje HomeMade cookers**, this becomes charmingly simple. Prepare your favourite food just like in a traditional wood-burning oven or impress your family with a range of tasty experiences. We designed our cookers with **smart** and **user-friendly solutions**, so you can rely on them and just add your final touch.



HomeMade shape

All the qualities of baking in wood-burning ovens

The characteristic rounded shape is one of the most beneficial features of Gorenje cookers. Inspired by traditional wood-burning ovens, it enables hot air to move around freely. Since the food is

heated evenly and from all sides, it is always perfectly done: crispy on the outside and juicy on the inside.



SuperSize

Ready for XXL recipes

Gorenje cookers offer enlarged baking surface and use of extra big trays. Innovative solutions enable optimised energy consumption and evenly cooked food, regardless of the quantity. Full oven width is efficiently used while superior technology makes sure the food is evenly done on all levels.



BigSpace

More space for greater cooking freedom

The increased capacity of the oven (up to 70 litres) allows preparing bigger quantities of food at the same time. The optimised airflow circulates inside the oven completely freely and with their BigSpace cavity Gorenje cookers can easily accommodate even a huge turkey.



TouchFree coating

Shiny and fingerprint-free finish

All stainless steel surfaces are coated with a special TouchFree film that prevents fingerprints markings, leaving the surface always shiny and making cleaning much easier.



OpenView

Excellent overview

Advanced and even double lighting featured in some models of cookers enable clear view of the large oven cavity. Combined with special design of the glass door, this brings excellent overview of the baking process.



XXL Storage drawer

Everything neatly within reach

A specially large and deep drawer for storing larger cookware or cooking utensils. Trays, baking pans, tableware - have everything you need at hand with this convenient and spacious storage solution.



GentleClose

A soft touch is enough

Only a soft touch is needed to close the cooker door smoothly, without any noise.



SilverMatte

Ultra resistant, ultra smooth coating

Enamel quality and type are exceptionally important for the cooker and its operation. SilverMatte is a highly resistant and strong material that can stand extreme heats. Free from micro pores, it coats oven cavity surfaces and baking trays, making them resistant to the highest temperatures. The coating of the interior supports heat reflection and provides additional insulation. Therefore, the oven interior always stays sterile and safe.



Mechanical door lock

Always on the safe side

A mechanical door lock on the oven door prevents opening during usage and thus makes the cooker even safer, especially when you have kids around. This lock is enclosed to the oven, so you can install and remove it as needed.



AquaClean

Simple, casual cleaning

Due to special high-quality enamel, AquaClean function brings even more efficient and user-friendly way of cleaning the oven cavity. All it takes is to pour half a litre of water into a baking tray and turn AquaClean on after each baking. In just 30 minutes, the results are visible on the entire surface and the baking trays. Stains and grease are softened and can be wiped away easily with a soft cloth.



SmartDoor Switch

SmartDoorSwitch automatically turns off the fan and all heaters when the oven door is opened during the cooking process. This prevents the blow of hot air from the oven cavity. When the door is closed again, heaters and the fan resume the baking process.



Smooth oven door

Simply removable oven door is free of any notches or edges that could harbour dirt, making cleaning quick and easy. Innovative design allows quick and practical removal and cleaning also the space between the glass layers.



ChildLock The kitchen as a safe environment

ChildLock option is excellent for those who have children at home. Leaving them in a kitchen unauthorized has never been safer, since this option prevents them from resetting any parameters or changing settings on display.



Special Programmes

Stay Warm Staying perfect for the latecomers

The StayWarm function keeps food at a constant temperature of 70°C until the time is right to serve the meal. The food retains its original flavour and temperature until it is served.

Defrost

In order to keep the food in perfect condition even after defrosting, it is very important to thaw it quickly and that the heat penetrates the core evenly and simultaneously. Safe defrosting is made possible by the defrost program. Use of a drip tray will also prevent undesired drops or spills of liquid. Place the frozen food on the oven rack in the middle of the oven. The drip tray placed into the lower guide will catch the dripping liquid.

Plate Warming Serve professional dishes in the comfort of your home

Warmed plates prevent the loss of flavour and ensure that food tastes every bit as good as it should: from soups to pastas and steamed vegetables. WarmPlate will keep your crockery at precisely the right temperature at 60°C. Enjoy professional service in the privacy of your home.

PERFECT TASTE WITH SPARK OF CREATIVITY

Gas Cooktop



Cooking like a chef can be simple. All it takes is a creative spark as Gorenje cooker with gas cooktop will take care of everything else. With its big surface, powerful burners and advanced features, it offers support for your wildest cooking endeavours. Ignite your inspiration and surprise your loved ones with perfect home-made dishes.



 **Wok Burner**
Powerful cooking, great authentic taste

New wok burner with special shape of gas crown directs flame directly to wok and enables even more powerful cooking with up to 4.0 kW power. Asian cuisine, vegetables and other dishes have never been so crisp and delicious, yet done so quickly.



 **ChefBurners**
More powerful and efficient cooking

New high-efficiency ChefBurners provide more efficient gas consumption and enable faster and eco-friendlier cooking. Different sizes of burners give you full flexibility, while their user-friendly positioning enables easy and safe cooking.



Big surface

Plenty of space for every pan or pot

Enlarged cooking surface (up to 20%) and longer distances between burners offer plenty of space for all sizes of pans and pots. Sleek and flat design allows easy sliding and using very big pots without disturbance, with perfect stability for all your cooking adventures.



Cast iron ProGrids

Strong, stable and durable support

Massive and elegant cast iron ProGrids are extremely stable and resistant even to the highest temperatures. They bring superior stability, durability and user-friendly design to your kitchen.

VARIETY OF HEATERS FOR BEST COOKING RESULTS

Hi-Light cooktop

Gorenje hi-light cooktops are designed as an easy-to-use tool that enables everyone to cook with great results. Efficient and smart, hi-light hobs are equipped with features that make cooking effortless. They offer double or oval cooking zones for best fit to your needs. With special features like residual heat indicators, timer and smart control they provide perfect control of the process and bring maximum safety.





ECP 97393 AX
Freestanding electric cooker

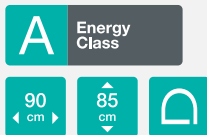

- Colour: Stainless steel
- Door material: Enamel



GI 9221 XF
Freestanding all gas cooker

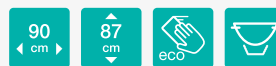

- Colour: Stainless steel
- Door material: Glass and aluminium
- Cover material: Glass

Efficiency	<ul style="list-style-type: none"> - Usable oven volume: 85 l - SuperSize baking area - HomeMADE® modelled on traditional wood-fired bread oven 	<ul style="list-style-type: none"> - SuperSize baking area
Control	<ul style="list-style-type: none"> - Electronic programming timer 	<ul style="list-style-type: none"> - Mechanical minute minder - One-hand ignition device for hob - Gas thermostat
Hob	<ul style="list-style-type: none"> - Glass ceramic hob 	<ul style="list-style-type: none"> - Gas hob - Wok triple burner
Cooking surface	<ul style="list-style-type: none"> - 5 HiLight heating zones - Left front: Ø 24 cm, 2,2 kW, - Right front: Ø 18 cm, 1,8 kW, - Left behind: Ø 18 cm, 1,2 kW, - Right behind: Ø 18 cm, 1,8 kW, - Center: 2,2 kW 	<ul style="list-style-type: none"> - 1 auxiliary burner + 2 semi rapid burner + 1 rapid burner + 1 triple burner - Left front: Ø 9 cm, 3 kW, - Right front: Ø 5 cm, 1 kW, - Left behind: Ø 7 cm, 1,75 kW, - Right behind: Ø 7 cm, 1,75 kW, - Center: Ø 13 cm, 3,3 kW - Type of pan support: Cast iron grid
Oven	<ul style="list-style-type: none"> - Multisystem oven BigSpace 	<ul style="list-style-type: none"> - Multifunction gas oven
Heating types		
Features	<ul style="list-style-type: none"> - Illumination - Baking on different levels at the same time 	<ul style="list-style-type: none"> - Illumination
Equipment	<ul style="list-style-type: none"> - 1 shallow enameled baking pan // 1 deep enameled baking pan - Wire shelf // 1x wire guides - Motorized turn spit 	<ul style="list-style-type: none"> - 1 shallow enameled baking pan // Wire shelf - 1x wire guides // Motorized turn spit - Catalytic fan cover
Safety	<ul style="list-style-type: none"> - Residual heat indicator - Triple glazed oven door with one heat deflector (CoolDoor) 	<ul style="list-style-type: none"> - Safety function - Double glazed oven door with one heat deflector (CompactDoor) - Gas control
EasyCleaning	<ul style="list-style-type: none"> - AquaClean 	<ul style="list-style-type: none"> - EcoClean enamel
Technical data	<ul style="list-style-type: none"> - Connected load: 11010 W - Dimensions (W×H×D): 90 × 85 × 60 cm - Dimensions of packed product (W×H×D): 96 × 85 × 69 cm - Net weight: 80 kg - Gross weight: 86,2 kg 	<ul style="list-style-type: none"> - Gas type: G30/30 - Dimensions (W×H×D): 90 × 87 × 60 cm - Dimensions of packed product (W×H×D): 94,5 × 85 × 68 cm - Net weight: 68 kg - Gross weight: 75,2 kg



EC 6340 XC
Freestanding electric cooker

Advanced Line

A Energy Class

60 cm 85 cm 71 l

Icons: D, X, DC, S, Fingerprint, Fingerprint

- Colour: Colour of brushed stainless steel
- Control panel material: Stainless steel
- Door material: Glass



GI 6320 XA
Freestanding all gas cooker

Essential Line

A Energy Class

60 cm 85 cm 64 l

Icons: D, X, DC, S, Fingerprint, Fingerprint, Bowl

- Colour: Colour of brushed stainless steel
- Control panel material: Stainless steel
- Door material: Glass // GentleClose door hinge
- Cover material: Glass

Efficiency	<ul style="list-style-type: none"> - Usable oven volume: 71 l - SuperSize baking area - Surface of the largest baking pan: 1316 cm² - HomeMADE® modelled on traditional wood-fired bread oven 	<ul style="list-style-type: none"> - Usable oven volume: 64 l - SuperSize baking area - Surface of the largest baking pan: 1316 cm² - HomeMADE® modelled on traditional wood-fired bread oven
Control	<ul style="list-style-type: none"> - Knob shape: Ergonomic knobs - IconLed 	<ul style="list-style-type: none"> - Knob shape: Ergonomic knobs // Electronic programming timer with the function of gas-burners switching-OFF // One-hand ignition device for hob and oven // Gas thermostat
Hob	- Glass ceramic hob	- Gas hob
Features		- Burner frames number: 2
Cooking surface	<ul style="list-style-type: none"> - 4 HiLight heating zones - Left front: Ø two ring 21/12 cm, 2,2 kW, - Right front: Ø 14,5 cm, 1,2 kW, - Left behind: Ø 14,5 cm, 1,2 kW, - Right behind: Ø 18 cm, 1,8 kW 	<ul style="list-style-type: none"> - 1 auxiliary burner + 1 double burner + 2 normal burners - Left front: Ø 4,6 cm, 1 kW, - Right front: Ø 13,2 cm, 3,5 kW, - Left behind: Ø 6,9 cm, 1,9 kW, - Right behind: Ø 6,9 cm, 1,9 kW - Type of pan support: Cast iron grid
Oven	- Multifunction oven - 71 l	- Gas oven - 64 l
Heating types		
Features	- Illumination	- Illumination // Closed door grilling
Equipment	<ul style="list-style-type: none"> - 1 shallow enameled baking pan // 1 deep enameled baking pan - Wire shelf // 1x wire guides 	<ul style="list-style-type: none"> - 1 shallow enameled baking pan // 1 deep enameled baking pan - Wire shelf // 1x wire guides
Safety	<ul style="list-style-type: none"> - Residual heat indicator // Thermoelectric fuse // Dynamic oven cooling - DC // Double glazed oven door with one heat deflector (CompactDoor) 	<ul style="list-style-type: none"> - Thermoelectric fuse // Double glazed oven door with one heat deflector (CompactDoor) // Gas control
EasyCleaning	<ul style="list-style-type: none"> - AquaClean function // SilverMatte // TouchFree Inox - Removable flat oven inner door glass surface 	<ul style="list-style-type: none"> - AquaClean // SilverMatte // TouchFree Inox - Removable flat oven inner door glass surface
Technical data	<ul style="list-style-type: none"> - Connected load: 9100 W - Energy consumption: 0,88 kWh (venting), 0,92 kWh (conventional) - Dimensions (W×H×D): 60 × 85 × 60 cm - Dimensions of packed product (W×H×D): 67,6 × 96 × 71,9 cm - Net weight: 46,3 kg - Gross weight: 51,3 kg 	<ul style="list-style-type: none"> - Energy consumption: 1,67 kWh (conventional) - Energy consumption gas oven: 6,01 MJ - Gas type: G30/30 - Dimensions (W×H×D): 60 × 85 × 60 cm - Dimensions of packed product (W×H×D): 67,6 × 96 × 71,9 cm - Net weight: 50,7 kg - Gross weight: 55,7 kg



GI 6120 SJ
Freestanding all gas cooker

Essential Line



- Colour: Metallic grey
- Control panel material: Varnished metal
- Door material: Glass
- GentleClose door hinge
- Cover material: Glass



E 6120 SD
Freestanding electric cooker

Essential Line

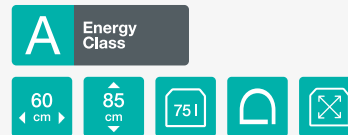

- Colour: Metallic grey
- Control panel material: Varnished metal
- Door material: Glass
- Cover material: Glass

Efficiency	<ul style="list-style-type: none"> - Usable oven volume: 60 l - Surface of the largest baking pan: 1316 cm² - HomeMADE® modelled on traditional wood-fired bread oven 	<ul style="list-style-type: none"> - Usable oven volume: 75 l - SuperSize baking area - Surface of the largest baking pan: 1316 cm² - HomeMADE® modelled on traditional wood-fired bread oven
Control	<ul style="list-style-type: none"> - Knob shape: Ergonomic knobs - Two-hand ignition device for hob and oven // Gas thermostat 	<ul style="list-style-type: none"> - Knob shape: Ergonomic knobs
Hob	<ul style="list-style-type: none"> - Gas hob 	<ul style="list-style-type: none"> - Electric hob
Features	<ul style="list-style-type: none"> - Burner frames number: 2 	
Cooking surface	<ul style="list-style-type: none"> - 1 auxiliary burner + 1 large burner + 2 standard burners - Left front: Ø 4,6 cm, 1 kW, - Right front: Ø 9,4 cm, 3 kW, - Left behind: Ø 6,9 cm, 1,9 kW, - Right behind: Ø 6,9 cm, 1,9 kW - Type of pan support: Enameled 	<ul style="list-style-type: none"> - 2 fast electric cooking zones + 1 normal electric zone + 1 normal electric zone with temperature restrainer - Left front: Ø 18 cm, 2 kW, - Right front: Ø 14,5 cm, 1,5 kW, - Left behind: Ø 14,5 cm, 1 kW, - Right behind: Ø 18 cm, 1,5 kW
Oven	<ul style="list-style-type: none"> - Gas oven - 60 l 	<ul style="list-style-type: none"> - Conventional oven - 75 l
Heating types		
Features	<ul style="list-style-type: none"> - Illumination // Closed door grilling 	<ul style="list-style-type: none"> - Illumination
Equipment	<ul style="list-style-type: none"> - 1 shallow enameled baking pan // 1 deep enameled baking pan - Wire shelf 	<ul style="list-style-type: none"> - 1 shallow enameled baking pan // 1 deep enameled baking pan - Wire shelf // 1x wire guides
Safety	<ul style="list-style-type: none"> - Thermoelectric fuse // Double glazed oven door with one heat deflector (CompactDoor) // Gas control 	<ul style="list-style-type: none"> - Thermoelectric fuse - Double glazed oven door with one heat deflector (CompactDoor)
EasyCleaning	<ul style="list-style-type: none"> - AquaClean // SilverMatte // TouchFree Inox - Removable flat oven inner door glass surface 	<ul style="list-style-type: none"> - AquaClean function - SilverMatte
Technical data	<ul style="list-style-type: none"> - Energy consumption: 1,67 kWh (conventional) - Energy consumption gas oven: 6,01 MJ - Gas type: G30/30 - Dimensions (W×H×D): 60 × 85 × 60 cm - Dimensions of packed product (W×H×D): 67,6 × 96 × 71,9 cm - Net weight: 45,1 kg - Gross weight: 50,1 kg 	<ul style="list-style-type: none"> - Connected load: 8700 W - Energy consumption: 0,88 kWh (conventional) - Dimensions (W×H×D): 60 × 85 × 60 cm - Dimensions of packed product (W×H×D): 67,6 × 96 × 71,9 cm - Net weight: 47,5 kg - Gross weight: 52,5 kg



MK 100 S-L

Pantry kitchen

A

 Energy
Class

 100
cm

 87.5
cm

Cooking compartment	<ul style="list-style-type: none"> - Behind cooking zone: 180 mm, 2 kW, fast electric hob - Front cooking zone: 145 mm, 1,5 kW, fast electric hob
Cooling compartment	<ul style="list-style-type: none"> - Total gross/net volume: 121 / 118 l - Capacity of freezer compartment: 17 l - Power cut safe time: 12 h
Technical data	<ul style="list-style-type: none"> - Connection power: 3500 W - Connected load of refrigerator: 70 W - Dimensions (W×H×D): 100 × 87,5 × 60 cm - Dimensions of packed product (W×H×D): 106 × 99 × 68 cm - Net weight: 57 kg - Gross weight: 63 kg - Connected load: 3570 W - Nominal current of fuse: 16 amp

PERSONAL FACTORY OF PERFECT TASTE

Ovens

Every Gorenje oven is a little wonder factory. A thousand physical processes take place in it, all controlled and perfectly coordinated to the end result - delicious food. Years of ambitious research into the physics behind baking, roasting and steaming have led to a wide range of features and functions that offer a unique cooking experience. These ovens are helpful personal assistants with a talent for details: an innovative shape that distributes hot air evenly, a monitoring device that cooks meat to perfection, a steaming tool that brings in just enough moisture. There are many interesting configurations to choose from, all of which are exceptionally user-friendly.







HomeMade shape

All the qualities of baking in wood-burning ovens

The characteristic rounded shape is one of the most beneficial features of Gorenje ovens. Inspired by traditional wood-burning ovens, it enables hot air to move around freely. Since the food is heated evenly and from all sides, it is always perfectly done:

crispy on the outside and juicy on the inside. Combined with the MultiFlow 360° ventilation system, it makes baking on all 5 levels possible.



MultiFlow 360°

All sides are good sides

MultiFlow 360° guarantees the optimal circulation of heat within the oven. Due to smartly positioned ventilation openings on the back wall and the unique round shape, air is spread evenly throughout the oven. The fan pushes hot air around the entire oven volume, making the food perfectly baked on all sides. The dynamic air movement allows simultaneous baking on many levels without smells and flavours mixing together.



Multi-level baking

Many dishes in one go

Combination of MultiFlow 360° and HomeMade shape helps reach the toughest objective: preparing five trays of dishes at once. The good news is: the flavors and smells don't mix. Smart air distribution ensures that the food is evenly baked on every level. Since the oven volume is larger, the overview is excellent as well. Superior models enable arranging the baking trays on five different levels.



AutoProgrammes

Select, touch, done

Gorenje ovens provide fully automatic cooking programme with over 80 recipes to choose from, ideal for beginners. The secret of auto mode is quite simple – all the parameters such as time, temperature, heaters, are automatically set. All that the user needs to do is choose the dish type and weight and press start. The oven will do the rest.



Step by step

Perfect food in 2, 3 or more steps

Cooking in phases is achieved by manually programming the many steps of the baking process. Throughout all the steps of the automatic cooking process there is no need to change the settings manually. It is also ideal for more experienced users and for dishes like bread and lasagne, which need temperature changes.

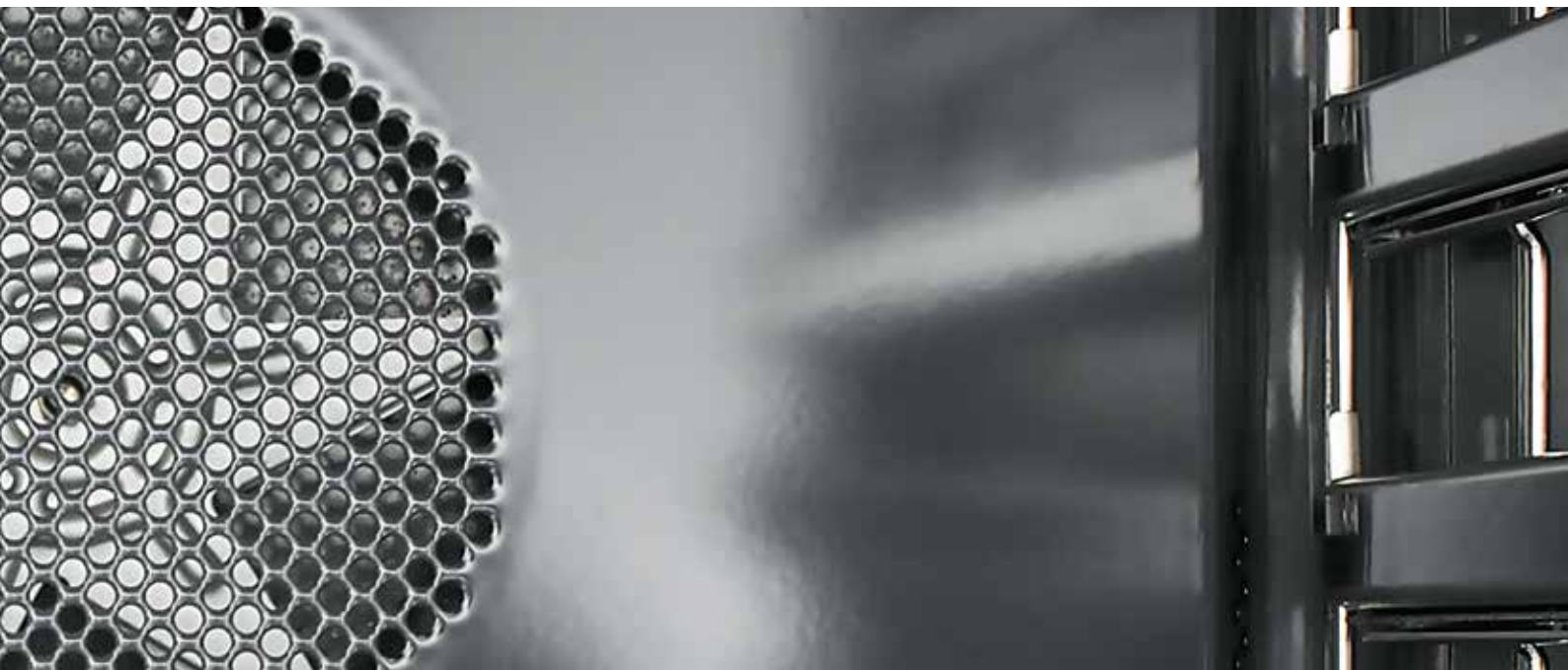

SilverMatte

Ultra resistant, ultra smooth coating

Enamel quality and type are exceptionally important for the oven and its operation. SilverMatte is a highly resistant and strong material that can stand extreme heats, even pyrolytic cleaning at 500 °C. Free from micro pores, it coats oven surfaces and

baking trays, making them resistant to the highest temperatures, microwaves and steam. The triple coating of the interior supports heat reflection and provides additional insulation. Therefore, the oven interior always stays sterile and safe.

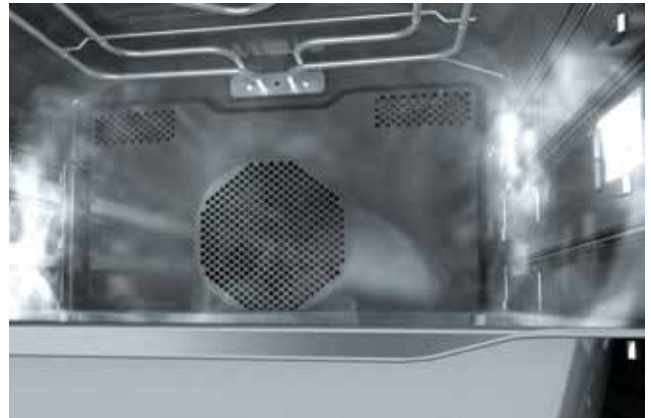

CataClean

A surface that stands no grease

Catalytic cleaning represents a great assistance in oven maintenance. When the oven reaches 85°C or more during the baking process, catalytic panels automatically start absorbing the grease and impurities.



AquaClean

Simple, casual cleaning

Due to completely new enamel in all lines of new Gorenje ovens, AquaClean function has been significantly improved. AquaClean offers great assistance in cleaning of the oven cavity. All it takes is to pour half a litre of water into a baking tray and turn AquaClean on after each baking. In just 30 minutes, the results are visible on the entire surface and the baking trays. Stains and grease are softened and can be wiped away more easily and the oven stays spotless.



BigSpace

More space for greater cooking freedom

The new generation of Gorenje ovens conceals a shape within the upper part. Now the optimised airflow circulates inside at an even greater volume, circling completely freely. The increased capacity allows preparation of larger baking trays and larger quantities of food, while their outside dimensions remain the same. Instead of the previous 3, the Superior oven now enables using 5 levels at the same time. Capacities range up to 75l in standard ovens and up to 53l in microwave ovens, which is amongst the largest available on the market.



GentleClose

Super easy and super silent

Only a soft touch is needed to close the oven door smoothly, without any noise.



Dehydration

Great food, always at hand

Dried fruit, vegetables, herbs and meat can be easily prepared at home. Dehydration is possible on up to 5 levels at the same time, which saves time and energy.



Yoghurt

A simple way to healthy stuff

A special function enables healthy yoghurt to be prepared at home. Automatic temperature and time settings provide optimal conditions that create homemade yoghurt in around 3 hours. This function requires the use of additional Gorenje accessories.



DC+ System

The DynamiCooling system efficiently cools the oven exterior (or housing) to prevent any damage caused by high temperature. In ovens with the DynamiCooling+ system, the heat sensors regulate the cooling of the oven exterior walls until they reach a temperature of 60 °C. This is particularly convenient in ovens with the pyrolytic cleaning function which works with extremely high temperatures.



UltraCoolDoor

Special triple or even quadruple glazing isolates the oven, making it even safer for children and pets. The heat is kept inside, optimising energy consumption by stopping heat escaping from the oven.



SuperSize

More spacious ovens allow you to cook a larger quantity of food – not only because of even air circulation at all levels, but also because of the 46cm wide baking trays in both standard and compact ovens. Innovative solutions allow a larger interior and the oven width is fully used. There is more space on each baking tray and the superior technology makes sure the food is cooked evenly on all levels.



TelescopicGuides

Smooth running telescopic guides provide a perfect overview of the process on all levels. This means safer and easier removal and cleaning. Gorenje ovens feature fully pulled out guides on three levels in Superior line. During the pyrolytic cleaning, they should be removed from the oven.



PerfectGrill

The best baking results are achieved with a combination of larger and smaller heaters, where the latter is positioned inside the larger one. The smart positioning of the heaters allows optimal heat distribution and provides the ultimate baking results every time, so food is crispy on the outside and soft on the inside. A variable heater combination can use either the inner or outer heater, or both at once. In advanced models, the heater is movable for easier cleaning and maintenance.



AutoRoast

The AutoRoast function first heats the oven to 230°C. The food is roasted for 30 minutes and then the temperature drops to the set level. A smart combination of time and temperature creates ideal roasting conditions. As a result, meat is crispy and well done on the outside and perfectly soft and tender on the inside.



MeatProbe

By controlling the temperature inside the meat, the MeatProbe manages the entire process and even activates the alarm when the time is right.



TouchFree coating

All stainless steel surfaces are coated with a special TouchFree film that prevents fingerprints markings, leaving the surface always shiny and making cleaning much easier.



FastPreheat

The oven reaches a temperature of up to 200°C in just 6 minutes, saving 30 % of the time needed by standard preheating. This comes in handy for recipes that require a preheated oven. A light and sound signal informs when the temperature is right.



SlowBake

SlowBake bakes food at low temperatures for up to 6 hours. Due to the long preparation periods, meat and fish are softened but retain their juiciness, aroma and nutrients.



BO 937 E20XG

Built-in single oven

Essential Line

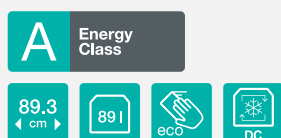

- Colour: Black
- Handle colour: Colour of stainless steel
- Control panel material: Glass

BO 935 E10X

Built-in single oven

Essential Line

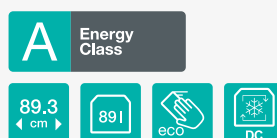

- Colour: Stainless steel
- Handle colour: Colour of aluminium
- Control panel material: Stainless steel

Efficiency	- Multifunction oven - 89 l - SuperSize baking area	- Multifunction oven - 89 l - SuperSize baking area
Control	- Mechanic temperature control - Knob shape: Ergonomic, not sinkable buttons - Electronic programming timer	- Mechanic temperature control - Knob shape: Ergonomic, not sinkable buttons - Electronic programming timer
Heating types		
Features	- Illumination	- Illumination - Baking on different levels at the same time
Equipment	- 1 deep enameled baking pan - 1 shallow enameled baking pan - Wire shelf - Partially extendable telescopic guides on one level - Motorized turn spit	- 1 shallow enameled baking pan - Wire shelf - 1x wire guides - Motorized turn spit
Safety	- Dynamic oven cooling - DC	- Dynamic oven cooling - DC
EasyCleaning	- Eco enamel (oven and baking tray)	- Eco enamel (oven and baking tray)
Technical data	- Dimensions (W×H×D): 89,3 × 47,7 × 53,8 cm - Dimensions of packed product (W×H×D): 97 × 54 × 67 cm - Niche dimensions (W×H×D): 86 × 48 × 56 cm - Net weight: 40 kg - Gross weight: 46 kg - Connected load: 3500 W	- Dimensions (W×H×D): 89,3 × 47,7 × 53,8 cm - Dimensions of packed product (W×H×D): 97 × 54 × 67 cm - Niche dimensions (W×H×D): 86 × 48 × 56 cm - Net weight: 40 kg - Gross weight: 46 kg - Connected load: 3400 W



BOG 932 A20FBG

Gas oven

Advanced Line



- Colour: Black
- Handle colour: Colour of brushed stainless steel
- Control panel material: Glass
- GentleClose door hinge



BOG 932 E10FX

Gas oven

Essential Line

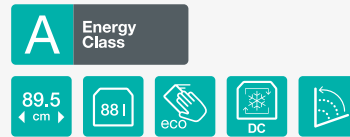

- Colour: Colour of brushed stainless steel
- Handle colour: Colour of brushed stainless steel
- Control panel material: Stainless steel
- GentleClose door hinge

Efficiency	<ul style="list-style-type: none"> - Multifunction gas oven – 88 l - SuperSize baking area 	<ul style="list-style-type: none"> - Multifunction gas oven – 88 l - SuperSize baking area
Control	<ul style="list-style-type: none"> - Mechanic temperature control - Touch control electronic programming timer 	<ul style="list-style-type: none"> - Mechanic temperature control - Electronic programming timer
Heating types		
Features	- Illumination	- Illumination
Equipment	<ul style="list-style-type: none"> - 1 deep enameled baking pan - 1 shallow enameled baking pan - Wire shelf - 1x wire guides - Partially extendable telescopic guides on one level - Motorized turn spit - Catalytic oven side 	<ul style="list-style-type: none"> - 1 shallow enameled baking pan - Wire shelf - 1x wire guides - Motorized turn spit
Safety	<ul style="list-style-type: none"> - Thermoelectric fuse - Dynamic oven cooling - DC 	<ul style="list-style-type: none"> - Thermoelectric fuse - Dynamic oven cooling - DC
EasyCleaning	- Eco enamel (oven and baking tray)	- Eco enamel (oven and baking tray)
Technical data	<ul style="list-style-type: none"> - Grill power: 2800 W - Dimensions (W×H×D): 89,5 × 59,4 × 55,1 cm - Dimensions of packed product (W×H×D): 98 × 65 × 65 cm - Niche dimensions (W×H×D): 86 × 59,5 × 56 cm - Net weight: 58 kg - Gross weight: 61,2 kg 	<ul style="list-style-type: none"> - Grill power: 2800 W - Dimensions (W×H×D): 89,5 × 59,4 × 55,1 cm - Dimensions of packed product (W×H×D): 98 × 65 × 65 cm - Niche dimensions (W×H×D): 86 × 59,5 × 56 cm - Net weight: 58 kg - Gross weight: 61,2 kg



BOG 922 E00FX

Gas oven

Essential Line

BOG 923 E10X

Built-in single oven

Essential Line

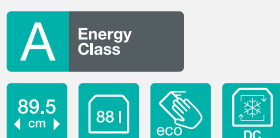

- Colour: Colour of brushed stainless steel
- Handle colour: Colour of brushed stainless steel
- Control panel material: Stainless steel
- Classic door hinge

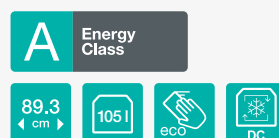

- Colour: Stainless steel
- Handle colour: Colour of aluminium
- Control panel material: Stainless steel
- Classic door hinge

Efficiency	- Multifunction gas oven – 88 l - SuperSize baking area	- Gas oven – 105 l - SuperSize baking area
Control	- Mechanic temperature control - Mechanical minute minder	- Knob shape: Ergonomic, not sinkable buttons - Mechanical minute minder
Heating types		
Features	- Illumination	- Illumination
Equipment	- 1 shallow enameled baking pan - Wire shelf - Drawn guides - Motorized turn spit	- 1 deep enameled baking pan - Wire shelf - 1x wire guides - Motorized turn spit
Safety	- Thermoelectric fuse - Dynamic oven cooling - DC	- Thermoelectric fuse - Dynamic oven cooling - DC
EasyCleaning	- Eco enamel (oven and baking tray)	- Eco enamel (oven and baking tray)
Technical data	- Grill power: 2800 W - Dimensions (W×H×D): 89,5 × 59,4 × 55,1 cm - Dimensions of packed product (W×H×D): 98 × 65 × 65 cm - Niche dimensions (W×H×D): 86 × 59,5 × 56 cm - Net weight: 58 kg - Gross weight: 61,2 kg	- Grill power: 1800 W - Dimensions (W×H×D): 89,5 × 59,4 × 57,2 cm - Dimensions of packed product (W×H×D): 100 × 65 × 65 cm - Niche dimensions (W×H×D): 86 × 59,5 × 56 cm - Net weight: 58 kg - Gross weight: 64 kg - Connected load: 1850 W



BO 799 S50X
Built-in single oven

Superior Line

Energy Class
 59.5 cm
 73 l
 UCD
 DC+
 TouchFree Inox
 AquaClean
 SilverMatte
 MultiFlow 360
 PerfectGrill
 HomeMADE
 SuperSize
 Step by Step
 Double lightning
 Baking on different levels
 MultiFlow 360

- Colour: Colour of brushed stainless steel
- Handle colour: Colour of brushed stainless steel
- Control panel material: Glass and stainless steel
- GentleClose door hinge

BO 798 S53X
Built-in single oven

Superior Line

Energy Class
 59.5 cm
 73 l
 UCD
 DC+
 Ergonomic knobs
 ProCook
 Auto programme
 TouchFree Inox
 AquaClean
 SilverMatte
 MultiFlow 360
 PerfectGrill
 HomeMADE
 SuperSize
 Step by Step
 Double lightning
 Baking on different levels
 MultiFlow 360

- Colour: Colour of brushed stainless steel
- Handle colour: Colour of brushed stainless steel
- Control panel material: Glass and stainless steel
- GentleClose door hinge

Efficiency	<ul style="list-style-type: none"> - Multifunction oven - 73 l - SuperSize baking area - Surface of the largest baking pan: 1316 cm² - HomeMADE® modelled on traditional wood-fired bread oven - PerfectGrill 	<ul style="list-style-type: none"> - Multifunction oven - 73 l - SuperSize baking area - Surface of the largest baking pan: 1316 cm² - HomeMADE® modelled on traditional wood-fired bread oven - PerfectGrill
Control	<ul style="list-style-type: none"> - Electronic control - HomeChef, electronic programme module - Auto programme 	<ul style="list-style-type: none"> - Electronic control - Knob shape: Ergonomic knobs - ProCook // Auto programme
Heating types		
Features	<ul style="list-style-type: none"> - Step by Step - Double lightning - Baking on different levels at the same time - MultiFlow 360° 	<ul style="list-style-type: none"> - Step by Step - Double lightning - Baking on different levels at the same time - MultiFlow 360°
Equipment	<ul style="list-style-type: none"> - 1 deep enameled baking pan - 2 shallow enameled baking pans - 1 glass baking pan - Wire shelf - Fully extendable telescopic guides on three levels - Meat Probe 	<ul style="list-style-type: none"> - 1 deep enameled baking pan - 2 shallow enameled baking pans - Wire shelf - Partially extendable telescopic guides on three levels - Meat Probe
Safety	<ul style="list-style-type: none"> - Thermoelectric fuse - Dynamic oven cooling plus - DC+ - Triple glazed oven door with double heat deflector (UltraCoolDoor) - Mechanic door safety bolt 	<ul style="list-style-type: none"> - Thermoelectric fuse - Dynamic oven cooling plus - DC+ - Triple glazed oven door with double heat deflector (UltraCoolDoor)
EasyCleaning	<ul style="list-style-type: none"> - AquaClean function - SilverMatte - TouchFree Inox - Removable flat oven inner door glass surface 	<ul style="list-style-type: none"> - AquaClean function - SilverMatte - TouchFree Inox - Removable flat oven inner door glass surface
Technical data	<ul style="list-style-type: none"> - Energy consumption: 0,7 kWh (venting), 0,94 kWh (conventional) - Grill power: 2700 W - Dimensions (W×H×D): 59,5 × 59,5 × 54,6 cm - Dimensions of packed product (W×H×D): 63,5 × 69,1 × 68 cm - Niche dimensions (W×H×D): 56 × 59 × 55 cm - Net weight: 41,2 kg - Gross weight: 45,5 kg - Connected load: 3400 W 	<ul style="list-style-type: none"> - Energy consumption: 0,7 kWh (venting), 0,94 kWh (conventional) - Grill power: 2700 W - Dimensions (W×H×D): 59,5 × 59,5 × 54,6 cm - Dimensions of packed product (W×H×D): 63,5 × 69,1 × 68 cm - Niche dimensions (W×H×D): 56 × 59 × 55 cm - Net weight: 39,8 kg - Gross weight: 44,1 kg - Connected load: 3400 W



BO 747 S30X

Built-in single oven

Superior Line



- Colour: Colour of brushed stainless steel
- Handle colour: Colour of brushed stainless steel
- Control panel material: Glass and stainless steel
- GentleClose door hinge



BO 758 A30XG

Built-in single oven

Advanced Line

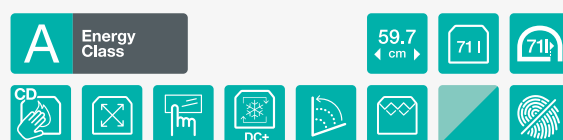

- Colour: Colour of brushed stainless steel
- Handle colour: Colour of brushed stainless steel
- Control panel material: Glass and stainless steel
- GentleClose door hinge

Efficiency	<ul style="list-style-type: none"> - Multifunction oven - 73 l - SuperSize baking area - Surface of the largest baking pan: 1316 cm² - HomeMADE® modelled on traditional wood-fired bread oven - PerfectGrill 	<ul style="list-style-type: none"> - Multifunction oven - 71 l - SuperSize baking area - Surface of the largest baking pan: 1316 cm² - HomeMade Plus shape - PerfectGrill
Control	<ul style="list-style-type: none"> - Electronic control - Knob shape: Illuminated sinkable knobs - IconTouch 	<ul style="list-style-type: none"> - Electronic control - DirecTouch
Heating types		
Features	<ul style="list-style-type: none"> - Illumination - Baking on different levels at the same time - MultiFlow 360° 	<ul style="list-style-type: none"> - Illumination - Baking on different levels at the same time
Equipment	<ul style="list-style-type: none"> - 1 deep enameled baking pan - 2 shallow enameled baking pans - Wire shelf - Fully extendable telescopic guides on two levels - Meat Probe 	<ul style="list-style-type: none"> - 1 deep enameled baking pan - 1 shallow enameled baking pan - Wire shelf - Partially extendable telescopic guides on two levels - Catalytic oven side
Safety	<ul style="list-style-type: none"> - Thermoelectric fuse - Dynamic oven cooling plus - DC+ - Triple glazed oven door with double heat deflector (UltraCoolDoor) 	<ul style="list-style-type: none"> - Thermoelectric fuse - Dynamic oven cooling plus - DC+ - Triple glazed oven door with one heat deflector (CoolDoor)
EasyCleaning	<ul style="list-style-type: none"> - AquaClean function - SilverMatte - TouchFree Inox - Removable flat oven inner door glass surface 	<ul style="list-style-type: none"> - Catalytic cleaning CataClean // AquaClean function - SilverMatte - TouchFree Inox - Removable flat oven inner door glass surface
Technical data	<ul style="list-style-type: none"> - Energy consumption: 0,7 kWh (venting), 0,94 kWh (conventional) - Grill power: 2700 W - Dimensions (W×H×D): 59,5 × 59,5 × 54,6 cm - Dimensions of packed product (W×H×D): 63,5 × 69,1 × 68 cm - Niche dimensions (W×H×D): 56 × 59 × 55 cm - Net weight: 39,2 kg - Gross weight: 43,5 kg - Connected load: 3400 W 	<ul style="list-style-type: none"> - Energy consumption: 0,81 kWh (venting), 0,92 kWh (conventional) - Grill power: 2700 W - Dimensions (W×H×D): 59,7 × 59,5 × 54,7 cm - Dimensions of packed product (W×H×D): 63,5 × 69,1 × 68 cm - Niche dimensions (W×H×D) (min-max): 56-56,8 × 58,3-60 × 55 cm - Net weight: 33,7 kg - Gross weight: 38 kg - Connected load: 3300 W



BO 737 E30XG

Built-in single oven

Essential Line

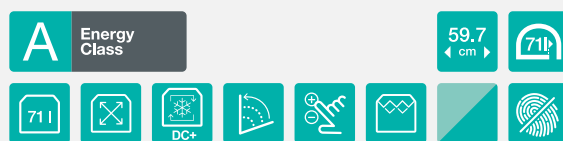

- Colour: Colour of brushed stainless steel
- Handle colour: Colour of brushed stainless steel
- Control panel material: Glass and stainless steel
- GentleClose door hinge

BO 737 E30X

Built-in single oven

Essential Line

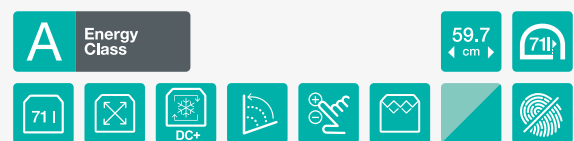

- Colour: Colour of brushed stainless steel
- Handle colour: Colour of brushed stainless steel
- Control panel material: Stainless steel
- GentleClose door hinge

Efficiency	<ul style="list-style-type: none"> - Multifunction oven - 71 l - SuperSize baking area - Surface of the largest baking pan: 1316 cm² - HomeMade Plus shape - PerfectGrill 	<ul style="list-style-type: none"> - Multifunction oven - 71 l - SuperSize baking area - Surface of the largest baking pan: 1316 cm² - HomeMade Plus shape - PerfectGrill
Control	<ul style="list-style-type: none"> - Mechanic temperature control - Knob shape: Sinkable knobs - IconLed 	<ul style="list-style-type: none"> - Mechanic temperature control - Knob shape: Sinkable knobs - IconLed
Heating types		
Features	<ul style="list-style-type: none"> - Illumination - Baking on different levels at the same time 	<ul style="list-style-type: none"> - Illumination - Baking on different levels at the same time
Equipment	<ul style="list-style-type: none"> - 1 deep enameled baking pan - 1 shallow enameled baking pan - Wire shelf - Partially extendable telescopic guides on two levels 	<ul style="list-style-type: none"> - 1 deep enameled baking pan - 1 shallow enameled baking pan - Wire shelf - Partially extendable telescopic guides on two levels
Safety	<ul style="list-style-type: none"> - Thermoelectric fuse - Dynamic oven cooling plus - DC+ - Double glazed oven door with one heat deflector (CompactDoor) 	<ul style="list-style-type: none"> - Thermoelectric fuse - Dynamic oven cooling plus - DC+ - Double glazed oven door with one heat deflector (CompactDoor)
EasyCleaning	<ul style="list-style-type: none"> - AquaClean function - SilverMatte - TouchFree Inox - Removable flat oven inner door glass surface 	<ul style="list-style-type: none"> - AquaClean function - SilverMatte - TouchFree Inox - Removable flat oven inner door glass surface
Technical data	<ul style="list-style-type: none"> - Energy consumption: 0,81 kWh (venting), 0,92 kWh (conventional) - Grill power: 2700 W - Dimensions (W×H×D): 59,7 × 59,5 × 54,7 cm - Dimensions of packed product (W×H×D): 63,5 × 69,1 × 68 cm - Niche dimensions (W×H×D) (min-max): 56-56,8 × 58,3-60 × 55 cm - Net weight: 30,7 kg - Gross weight: 35 kg - Connected load: 3300 W 	<ul style="list-style-type: none"> - Energy consumption: 0,81 kWh (venting), 0,92 kWh (conventional) - Grill power: 2700 W - Dimensions (W×H×D): 59,7 × 59,5 × 54,7 cm - Dimensions of packed product (W×H×D): 63,5 × 69,1 × 68 cm - Niche dimensions (W×H×D) (min-max): 56-56,8 × 59 × 55 cm - Net weight: 30,4 kg - Gross weight: 34,7 kg - Connected load: 3300 W



BO 736 E20X

Built-in single oven

Essential Line

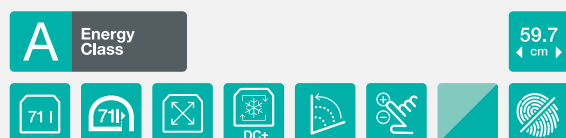

- Colour: Colour of brushed stainless steel
- Handle colour: Colour of brushed stainless steel
- Control panel material: Stainless steel
- GentleClose door hinge



BO 735 E11XK

Built-in single oven

Essential Line

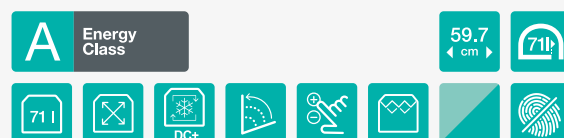

- Colour: Colour of brushed stainless steel
- Handle colour: Colour of brushed stainless steel
- Control panel material: Stainless steel
- GentleClose door hinge

Efficiency	<ul style="list-style-type: none"> - Multifunction oven - 71 l - SuperSize baking area - Surface of the largest baking pan: 1316 cm² - HomeMade Plus shape 	<ul style="list-style-type: none"> - Multifunction oven - 71 l - SuperSize baking area - Surface of the largest baking pan: 1316 cm² - HomeMade Plus shape - PerfectGrill
Control	<ul style="list-style-type: none"> - Mechanic temperature control - Knob shape: Sinkable knobs - IconLed 	<ul style="list-style-type: none"> - Mechanic temperature control - Knob shape: Ergonomic knobs - IconLed
Heating types		
Features	<ul style="list-style-type: none"> - Illumination - Baking on different levels at the same time 	<ul style="list-style-type: none"> - Illumination
Equipment	<ul style="list-style-type: none"> - 1 deep enameled baking pan - 1 shallow enameled baking pan - Wire shelf - Partially extendable telescopic guides on one level 	<ul style="list-style-type: none"> - 1 deep enameled baking pan - 1 shallow enameled baking pan - Wire shelf - 1x wire guides
Safety	<ul style="list-style-type: none"> - Thermoelectric fuse - Dynamic oven cooling plus - DC+ - Double glazed oven door with one heat deflector (CompactDoor) 	<ul style="list-style-type: none"> - Thermoelectric fuse - Dynamic oven cooling plus - DC+ - Double glazed oven door with one heat deflector (CompactDoor)
EasyCleaning	<ul style="list-style-type: none"> - AquaClean function - SilverMatte - TouchFree Inox - Removable flat oven inner door glass surface 	<ul style="list-style-type: none"> - AquaClean function - SilverMatte - TouchFree Inox
Technical data	<ul style="list-style-type: none"> - Energy consumption: 0,81 kWh (venting), 0,92 kWh (conventional) - Dimensions (W×H×D): 59,7 × 59,5 × 54,7 cm - Dimensions of packed product (W×H×D): 63,5 × 69,1 × 68 cm - Niche dimensions (W×H×D) (min-max): 56-56,8 × 58,3-60 × 55 cm - Net weight: 29,7 kg - Gross weight: 34 kg - Connected load: 2200 W 	<ul style="list-style-type: none"> - Energy consumption: 0,81 kWh (venting), 0,92 kWh (conventional) - Grill power: 2700 W - Dimensions (W×H×D): 59,7 × 59,5 × 56,5 cm - Dimensions of packed product (W×H×D): 63,5 × 69,1 × 68 cm - Niche dimensions (W×H×D) (min-max): 56-56,8 × 59-60 × 55 cm - Net weight: 29,7 kg - Gross weight: 34 kg - Connected load: 2700 W



BO 615 E01XK

Built-in single oven

Essential Line



- Colour: Colour of brushed stainless steel
- Handle colour: Colour of brushed stainless steel
- Control panel material: Glass and stainless steel
- Classic door hinge

Efficiency	<ul style="list-style-type: none"> - Multifunction oven - 61 l - SuperSize baking area - Surface of the largest baking pan: 1316 cm² - HomeMADE® modelled on traditional wood-fired bread oven - PerfectGrill
Control	<ul style="list-style-type: none"> - Mechanic temperature control - Knob shape: Ergonomic knobs
Heating types	
Features	<ul style="list-style-type: none"> - Illumination
Equipment	<ul style="list-style-type: none"> - 1 deep enameled baking pan - Wire shelf - Drawn guides
Safety	<ul style="list-style-type: none"> - Thermoelectric fuse - Dynamic oven cooling - DC - Double glazed oven door with one heat deflector (CompactDoor)
EasyCleaning	<ul style="list-style-type: none"> - AquaClean function - SilverMatte - TouchFree Inox - Removable flat oven inner door glass surface
Technical data	<ul style="list-style-type: none"> - Energy consumption: 0,86 kWh (venting), 0,92 kWh (conventional) - Grill power: 2700 W - Dimensions (W×H×D): 59,7 × 59,5 × 54,7 cm - Dimensions of packed product (W×H×D): 63,5 × 69,1 × 68 cm - Niche dimensions (W×H×D) (min-max): 56-56,8 × 58,3-60 × 55 cm - Net weight: 27,4 kg - Gross weight: 31,7 kg - Connected load: 2700 W



BOG 632 A20FBG

Gas oven

Advanced Line



- Colour: Black
- Handle colour: Colour of brushed stainless steel
- Control panel material: Glass
- GentleClose door hinge



BOG 632 E10FX

Gas oven

Essential Line



- Colour: Colour of brushed stainless steel
- Handle colour: Colour of brushed stainless steel
- Control panel material: Stainless steel
- GentleClose door hinge

Efficiency	- Multifunction gas oven - 54 l - SuperSize baking area	- Multifunction gas oven - 54 l - SuperSize baking area
Control	- Mechanic temperature control - Touch control electronic programming timer	- Mechanic temperature control - Electronic programming timer
Heating types		
Features	- Illumination	- Illumination
Equipment	- 2 shallow enameled baking pans - Wire shelf - 1x wire guides - Partially extendable telescopic guides on one level - Motorized turn spit - Catalytic oven side	- 1 shallow enameled baking pan - Wire shelf - 1x wire guides - Motorized turn spit
Safety	- Thermoelectric fuse - Dynamic oven cooling - DC	- Thermoelectric fuse - Dynamic oven cooling - DC
EasyCleaning	- EcoClean enamel	- EcoClean enamel
Technical data	- Grill power: 2200 W - Dimensions (W×H×D): 59,4 × 59,4 × 55,6 cm - Dimensions of packed product (W×H×D): 65 × 65 × 65 cm - Niche dimensions (W×H×D): 56 × 59,5 × 56 cm - Net weight: 35 kg - Gross weight: 37,3 kg	- Grill power: 2200 W - Dimensions (W×H×D): 59,4 × 59,4 × 55,6 cm - Dimensions of packed product (W×H×D): 65 × 65 × 65 cm - Niche dimensions (W×H×D): 56 × 59,5 × 56 cm - Net weight: 35 kg - Gross weight: 37,3 kg



BOG 622 E00FX

Gas oven

Essential Line

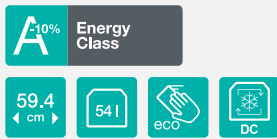

- Colour: Colour of brushed stainless steel
- Handle colour: Colour of brushed stainless steel
- Control panel material: Stainless steel
- Classic door hinge



BOG 633 E00XGK

Gas oven

Essential Line



- Colour: Black
- Handle colour: Colour of aluminium
- Control panel material: Glass
- Classic door hinge

Efficiency	- Multifunction gas oven - 54 l - SuperSize baking area	- Gas oven - 61 l - SuperSize baking area
Control	- Mechanic temperature control - Mechanical minute minder	- Mechanic temperature control - Electronic programming timer
Heating types		
Features	- Illumination	- Illumination
Equipment	- 1 shallow enameled baking pan - Wire shelf - Drawn guides - Motorized turn spit	- 1 deep enameled baking pan - 1 shallow aluminium baking pan - Wire shelf - Drawn guides - Motorized turn spit
Safety	- Thermoelectric fuse - Dynamic oven cooling - DC	- Thermoelectric fuse - Dynamic oven cooling - DC
EasyCleaning	- EcoClean enamel	- EcoClean enamel
Technical data	- Grill power: 2200 W - Dimensions (W×H×D): 59,4 × 59,4 × 55,6 cm - Dimensions of packed product (W×H×D): 65 × 65 × 65 cm - Niche dimensions (W×H×D): 56 × 59,5 × 56 cm - Net weight: 35 kg - Gross weight: 37,3 kg	- Grill power: 1200 W - Dimensions (W×H×D): 59,4 × 59,4 × 55,6 cm - Dimensions of packed product (W×H×D): 65 × 65 × 65 cm - Niche dimensions (W×H×D): 56 × 59,5 × 56 cm - Net weight: 33 kg - Gross weight: 35 kg - Connected load: 1225 W



BOG 623 E00X

Gas oven

Essential Line

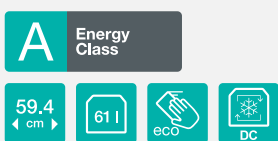

- Colour: Stainless steel
- Handle colour: Colour of aluminium
- Control panel material: Varnished metal
- Classic door hinge

Efficiency	- Gas oven - 61 l - SuperSize baking area
Control	- Mechanic temperature control - Mechanical minute minder
Heating types	
Features	- Illumination
Equipment	- 1 deep enameled baking pan - 1 shallow aluminium baking pan - Wire shelf - Drawn guides - Motorized turn spit
Safety	- Thermoelectric fuse - Dynamic oven cooling - DC - Mechanic door safety bolt
EasyCleaning	- EcoClean enamel
Technical data	- Grill power: 1200 W - Dimensions (W×H×D): 59,4 × 59,4 × 55,6 cm - Dimensions of packed product (W×H×D): 65 × 65 × 65 cm - Niche dimensions (W×H×D): 56 × 59,5 × 56 cm - Net weight: 33 kg - Gross weight: 35 kg - Connected load: 1225 W

THE WORLD'S GENTLEST TREATMENT FOR VITAMINS

Combi steam ovens

Cooking is an enormously complex process. Here many different things happen and countless circumstances collide. It takes a lot of scientific knowledge and years of development to come up with features and functions that are able to treat food not only as a robust energy source but also as a delicate source of vitamins, minerals, fibres and, of course, smells, tastes and pleasures. Gorenje combi ovens thus include a promise of healthy food, food made with respect for all its valuable ingredients and with a focus on the needs of the body. Gorenje steam ovens include standard and compact models.







WaterTank

Water at hand

The large, practical and elegant water tank is easily accessible and can be refilled even during the cooking process, without ever interrupting it. The 1.3l tank is smartly positioned for easier handling and designed to offer more space and prevent spilling. The capacity is sufficient for the longest steaming programmes. It can be easily dismantled and cleaned in the dishwasher.

PureSteam

No water, just steam

Gorenje combi steam ovens feature an excellent steaming performance that produces steam without any drops of water. Gorenje steam ovens are completely free from water in the oven cavity, thanks to the steam generator which extracts water from steam, leaving it completely clean. A cloud of pure steam is distributed all over the oven, without any drops of water that could spoil the food, making it soggy. It is also perfect for defrosting since warm steam evenly surrounds the food without creating hot spots.

MultiSteam 360°

A holistic approach to steaming

The same ventilation system used in conventional ovens, MultiFlow 360°, is used in steam ovens. After the steam enters the oven cavity through multiple openings, a special fan distributes the steam evenly, giving the food a soft and tender

Descaling

Limescale is not a problem

The descaling function operates automatically. When needed, it reminds the user to run the descaling process. After a special descaling solution is added, it takes only 1 hour to complete the process.



feel. One water tank is enough for the entire cooking process so no additional opening of the oven is needed, saving time and energy and improving the overall steaming results.



BCS 798 S24X Superior Line

Built-in combined steam oven



- Colour: Colour of brushed stainless steel
- Handle colour: Colour of brushed stainless steel
- Control panel material: Glass and stainless steel
- GentleClose door hinge



BCS 598 S24X Superior Line

Built-in combined compact steam oven



- Colour: Colour of brushed stainless steel
- Handle colour: Colour of brushed stainless steel
- Control panel material: Glass and stainless steel
- GentleClose door hinge

Efficiency	<ul style="list-style-type: none"> - Combined steam oven BigSpace - 73 l - SuperSize baking area - HomeMADE® modelled on traditional wood-fired bread oven - PerfectGrill - MultiSteam 360° 	<ul style="list-style-type: none"> - Compact steam oven - 50 l - SuperSize baking area - HomeMADE® modelled on traditional wood-fired bread oven - PerfectGrill - MultiSteam 360°
Control	<ul style="list-style-type: none"> - Electronic control - Knob shape: Ergonomic knobs - ProCook 	<ul style="list-style-type: none"> - Electronic control - Knob shape: Ergonomic knobs - ProCook
Heating types		
Features	<ul style="list-style-type: none"> - Step by Step - PureSteam - Double lightning - Baking on different levels at the same time - MultiFlow 360° 	<ul style="list-style-type: none"> - Step by Step - PureSteam - Double lightning - Baking on different levels at the same time - MultiFlow 360°
Equipment	<ul style="list-style-type: none"> - 1 deep enameled baking pan // 1 shallow enameled baking pan - 1 perforated steam tray // Wire shelf - Fully extendable telescopic guides on one level - Meat Probe // Water container: 1,3 l // SousVide 	<ul style="list-style-type: none"> - 1 deep enameled baking pan // 1 shallow enameled baking pan - 1 perforated steam tray // Wire shelf - Fully extendable telescopic guides on one level - Meat Probe // Water container: 1,3 l // SousVide
Safety	<ul style="list-style-type: none"> - Thermoelectric fuse - Dynamic oven cooling plus - DC+ - Triple glazed oven door with double heat deflector (UltraCoolDoor) 	<ul style="list-style-type: none"> - Thermoelectric fuse - Dynamic oven cooling plus - DC+ - Triple glazed oven door with double heat deflector (UltraCoolDoor)
EasyCleaning	<ul style="list-style-type: none"> - AquaClean function - Descaling - SilverMatte - TouchFree Inox - Removable flat oven inner door glass surface 	<ul style="list-style-type: none"> - AquaClean function - Descaling - SilverMatte - TouchFree Inox - Removable flat oven inner door glass surface
Technical data	<ul style="list-style-type: none"> - Energy consumption: 0,7 kWh (venting), 0,94 kWh (conventional) - Grill power: 2700 W - Dimensions (W×H×D): 59,5 × 59,5 × 54,6 cm - Dimensions of packed product (W×H×D): 63,5 × 69,1 × 68 cm - Niche dimensions (W×H×D): 56 × 59 × 55 cm - Net weight: 42,4 kg - Gross weight: 46,7 kg - Connected load: 3400 W 	<ul style="list-style-type: none"> - Energy consumption: 0,62 kWh (venting), 0,82 kWh (conventional) - Grill power: 2200 W - Dimensions (W×H×D): 59,5 × 45,5 × 54,6 cm - Dimensions of packed product (W×H×D): 63,5 × 54,1 × 68 cm - Niche dimensions (W×H×D): 56 × 45 × 55 cm - Net weight: 35 kg - Gross weight: 39,3 kg - Connected load: 2600 W

NOTHING BUT PLEASURE

Coffee machines

Perfect coffee is a serious challenge. Coffee beans need to be ground carefully, water temperature and the pressure needs to be set with precision, milk has to be warm enough and foamed to perfection. Nevertheless, a coffee cup shouldn't be cold either. Gorenje coffee machines will make mornings more enjoyable. Thought out coffee making process will extract the optimal flavor and create the enchanting smell that will bring a perfect start of the day.







CoffeeBean

Easy mornings

The coffee bean container is easily accessible as it can be pulled out. When needed ground coffee can also be used instead of beans. When the machine runs out of coffee beans, a warning will appear on the display.



EasyMilk

Creamy milk foam always at hand

Gorenje coffee machines feature a large milk container for cappuccino or latte, both can be prepared with desired amount of milk. A large milk container allows several cups of hot milk to be made without the need to refill. It is easily removable and can be simply pulled out and stored in the refrigerator until the next time you need it.



AutoCappuccino

From cappuccino to latte, in a second

The AutoCappuccino feature forces the water through ground coffee beans in a way that extracts the full aroma and creates truly genuine flavour. The desired level of milk foam can be set.



GrindingLevels

From dark beans to aromatic coffee

Coffee tastes best when made with freshly ground coffee beans. Gorenje coffee machines offer 9 different grinding levels, from super fine to extra coarse. The leftover pulp is automatically dispensed.



CMA 9200 UX
Automatic built-in coffee machine



- Colour: Colour of brushed stainless steel



WD 1410 X
Warming drawer

Superior Line



- Colour: Colour of brushed stainless steel

Efficiency	- Brewing / steam heating time: 2 min	- Number of servings: Set for 6 persons or 20 dishes in diameter 28 cm or 80 coffee cups or 40 tea cups - Capacity: 6 servings
Control	- Touch control - LCD display - Timer function - Coffee preparation mode: Bean and ground	- Touch control
Features	- Autocappuccino function - Number of different shots of espresso coffee: 3 - Own coffee setting according to the recipe - Possibility of 2 simultaneous brewed cups - Milk frothing option	- TouchFree Inox - Air vented circulation - Time setting: Stop - Variable temperature - Cold front - Drawer bottom: Glass
EasyCleaning	- Descaling programme	
Equipment	- Beans container: 200 g - Water container capacity: 1,8 l - Removable milk container - Tea brewing option	
Functions / Operating		- Warming of plates - Warming of cups - Heat preservation - Defrosting of food - Yoghurt - Manual setting of temperature and timer
Safety	- Automatic shut down	
Technical data	- Container water intake - Pump pressure: 15 bar - Dimensions (W×H×D): 59,5 × 45,5 × 38,1 cm - Dimensions of packed product (W×H×D): 65 × 54 × 51 cm - Niche dimensions (W×H×D): 56 × 45 × 55 cm - Net weight: 22,6 kg - Gross weight: 27,2 kg - Connected load: 1350 W	- Usable volume: 19,8 l - Temperature range: 40 – 80 °C - Timer range: 60 – 240 min - Dimensions (W×H×D): 59,5 × 14 × 56 cm - Dimensions of packed product (W×H×D): 65 × 23,5 × 67 cm - Niche dimensions (W×H×D) (min-max): 56-56,8 × 14 × 55 cm - Net weight: 18 kg - Gross weight: 19,7 kg - Connected load: 410 W

A MULTI-TALENTED OVEN

Microwave ovens

A microwave oven is an indispensable tool in any modern kitchen. It allows preparing tasty and healthy food to support you in your life on the fast lane. Advanced technology makes sure the food is evenly thawed or heated. In addition to microwaves, these appliances also allow cooking with grill or hot air.

Thus, a built-in microwave oven can also be used as a conventional oven. Needless to say, they are equally impressive on the outside. They are designed to match the rest of Gorenje's built-in family of appliances.







Inverter Technology

Gentle treatment for tastier food

Because of Inverter technology the energy is evenly distributed instead of pulsating. As a result, the food retains its initial structure, including its vitamins, minerals and fibres. The advantages of the even energy distribution are particularly

welcome when reheating or defrosting, and when cooking liquids. The overall microwaving time is shorter, which lowers energy consumption as well.



Stirrer Technology

Trays of all sizes are welcome

The Stirrer technology permits a standard-size baking tray to be placed in a microwave oven. The oven's entire width is used, saying goodbye to conventional turntables and uneven heating. The advanced microwave distribution system heats the food uniformly across the entire volume. Stirrer technology is available in both combi and standard microwave ovens.



MultiUse

Built-in combined and microwave ovens deliver all the advantages of microwaves, hot air, and grill. The five-level microwave power setting speeds up the cooking process while the hot air makes sure the food is well done. Combined operation, using grill and hot air at the same time, leads to excellent results when cooking large chunks of white meat, while grill and microwave combination will speed up roasting smaller chunks of meat, baking pizzas etc. Built-in microwave oven can also be used as a conventional oven.

AquaClean

Due to completely new enamel in all lines of new Gorenje ovens, AquaClean function has been significantly improved. AquaClean offers great assistance in cleaning of the oven cavity. All it takes is to pour half a litre of water into a baking tray and turn AquaClean on after each baking. In just 30 minutes, the results are visible on the entire surface and the baking trays. Stains and grease are softened and can be wiped away more easily and the oven stays spotless.

Smooth door

Microwave oven door is free from any notches or edges that could harbour impurities. The interior glass panel is removable. Such design allows keeping the door clean even with simple wiping.





BCM 598 S18X Superior Line
Built-in combined compact microwave oven

BCM 547 S12X Superior Line
Built-in combined compact microwave oven



- Colour: Colour of brushed stainless steel
- Handle colour: Colour of brushed stainless steel
- Control panel material: Glass and varnished metal
- Classic door hinge

- Colour: Colour of brushed stainless steel
- Handle colour: Colour of brushed stainless steel
- Control panel material: Glass and stainless steel
- Classic door hinge

Efficiency	<ul style="list-style-type: none"> - Combined microwave oven - 50 l - SuperSize baking area - HomeMADE® modelled on traditional wood-fired bread oven - PerfectGrill - Microwave power: 1000 W 	<ul style="list-style-type: none"> - Combined microwave oven - 50 l - SuperSize baking area - HomeMADE® modelled on traditional wood-fired bread oven - Microwave power: 1000 W
Control	<ul style="list-style-type: none"> - Electronic control - Knob shape: Ergonomic knobs - ProCook 	<ul style="list-style-type: none"> - Electronic control - Knob shape: Illuminated sinkable knobs - IconTouch
Heating types		
Features	<ul style="list-style-type: none"> - Step by Step - MultiUse - Inverter technology - Stirrer technology - Double lightning - Baking on different levels at the same time - MultiFlow 360° 	<ul style="list-style-type: none"> - MultiUse - Inverter technology - Stirrer technology - Illumination - Baking on different levels at the same time - MultiFlow 360°
Equipment	<ul style="list-style-type: none"> - 1 shallow enameled baking pan - 1 glass baking pan - Wire shelf - 1x wire guides 	<ul style="list-style-type: none"> - 1 shallow enameled baking pan - 1 glass baking pan - Wire shelf - 1x wire guides
Safety	<ul style="list-style-type: none"> - Thermoelectric fuse - Dynamic oven cooling plus - DC+ - Triple glazing door with a protective grid 	<ul style="list-style-type: none"> - Thermoelectric fuse - Dynamic oven cooling plus - DC+ - Triple glazing door with a protective grid
EasyCleaning	<ul style="list-style-type: none"> - SilverMatte - TouchFree Inox - Removable flat oven inner door glass surface 	<ul style="list-style-type: none"> - SilverMatte - TouchFree Inox - Removable flat oven inner door glass surface
Technical data	<ul style="list-style-type: none"> - Grill power: 2200 W - Frequency microwave power: 2450 MHz - Dimensions (W×H×D): 59,5 × 45,5 × 54,6 cm - Dimensions of packed product (W×H×D): 63,5 × 54,1 × 68 cm - Niche dimensions (W×H×D): 56 × 45 × 55 cm - Net weight: 34 kg - Gross weight: 38,3 kg - Connected load: 3000 W 	<ul style="list-style-type: none"> - Grill power: 2200 W - Frequency microwave power: 2450 MHz - Dimensions (W×H×D): 59,5 × 45,5 × 54,6 cm - Dimensions of packed product (W×H×D): 63,5 × 54,1 × 68 cm - Niche dimensions (W×H×D): 56 × 45 × 55 cm - Net weight: 33,8 kg - Gross weight: 38,1 kg - Connected load: 3000 W



BM 5350 X

Built-in microwave oven

Essential Line

BM 251 S7XG

Built-in combined microwave oven

Superior Line

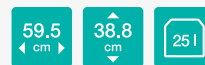
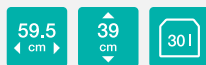

- Colour: Stainless steel
- Front panel material: Stainless steel
- Door material: Glass
- Stainless steel oven interior
- Left door opening
- Door open type: Button
- Double glazed oven door

- Colour: Black
- Front panel material: Glass
- Door material: Glass
- Stainless steel oven interior
- Left door opening
- Door open type: Button
- Double glazed oven door

Efficiency

- Oven volume: **30 l**
- SuperSize baking area
- Microwave power: **900 W**
- Power of upper infra heater: **1200 W**

- Oven volume: **25 l**
- Microwave power: **900 W**
- Power of upper infra heater: **1100 W**
- Number of infra heaters: 1
- Convection: **2500 W**
- Technology of producing microwaves: Standard technology (HVT)
- Type of microwave distribution: Rotating plate

Control

- Electronic control
- Input type: Button
- Type of display: LED display
- LogicalChoice

- Electronic control
- Input type: TouchControl
- Type of display: LCD display

Heating types



- Combined heating: Microwaves + grill



- Combined heating: Microwaves / Grill / Hot air

Features

- AUTO menu
- Defrost function by weight

- AUTO menu
- Time display

Safety

- ChildLock

- Door safety bolt

Equipment

- Rotating glass plate

- Rotating glass plate
- Rotating grid

Technical data

- Dimensions (W×H×D): **59,5 × 39 × 40 cm**
- Dimensions of packed product (W×H×D): **66 × 44,5 × 46,6 cm**
- Niche dimensions (W×H×D): **58 × 38 × 55 cm**
- Net weight: **17,5 kg**
- Gross weight: **18,5 kg**
- Connected load: **1450 W**

- Dimensions (W×H×D): **59,5 × 38,8 × 47 cm**
- Dimensions of packed product (W×H×D): **65,5 × 53,3 × 53,6 cm**
- Niche dimensions (W×H×D): **56,7 × 38 × 43 cm**
- Net weight: **21 kg**
- Gross weight: **23,5 kg**
- Connected load: **1450 W**



BM 171 A4XG

Built-in microwave oven

Advanced Line

BM 171 E2XG

Built-in microwave oven

Essential Line

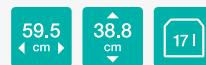
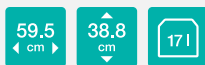

- Colour: Black
- Front panel material: Glass
- Door material: Glass
- Stainless steel oven interior
- Left door opening
- Door open type: Button
- Double glazed oven door

- Colour: Black
- Front panel material: Glass
- Door material: Glass
- Stainless steel oven interior
- Left door opening
- Door open type: Button
- Double glazed oven door

Efficiency

- Oven volume: **17 l**
- Microwave power: **700 W**
- Power of upper infra heater: **1000 W**
- Number of infra heaters: 1
- Technology of producing microwaves: Standard technology (HVT)
- Type of microwave distribution: Rotating plate

- Oven volume: **17 l**
- Microwave power: **700 W**
- Power of upper infra heater: **1000 W**
- Number of infra heaters: 1
- Technology of producing microwaves: Standard technology (HVT)
- Type of microwave distribution: Rotating plate

Control

- Electronic control
- Input type: Button, TouchControl
- Type of display: LED display

- Manual control
- Input type: Button

Heating types



- Combined heating: Microwaves + grill



- Combined heating: Microwaves + grill

Features

- AUTO menu
- Preinstalled programmes: 8
- Speed and auto defrost (by time and weight)
- Function Smart display
- Multi level cooking
- Time display

Safety

- Door safety bolt

- Door safety bolt

Equipment

- Rotating glass plate
- Rotating grid

- Rotating glass plate
- Rotating grid

Technical data

- Dimensions (W×H×D): **59,5 × 38,8 × 32 cm**
- Dimensions of packed product (W×H×D): **65 × 44,6 × 40,5 cm**
- Niche dimensions (W×H×D): **56,7 × 38 × 43 cm**
- Net weight: **14,5 kg**
- Gross weight: **16,5 kg**
- Connected load: **1250 W**

- Dimensions (W×H×D): **59,5 × 38,8 × 32 cm**
- Dimensions of packed product (W×H×D): **65 × 44,6 × 40,5 cm**
- Niche dimensions (W×H×D): **56,7 × 38 × 43 cm**
- Net weight: **14,5 kg**
- Gross weight: **17 kg**
- Connected load: **1050 W**



BM 171 E2X

Built-in microwave oven

Essential Line

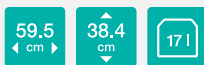

- Colour: Colour of brushed stainless steel
- Front panel material: Stainless steel
- Door material: Glass
- Stainless steel oven interior
- Left door opening
- Door open type: Button
- Double glazed oven door

Efficiency	<ul style="list-style-type: none"> - Oven volume: 17 l - Microwave power: 700 W - Power of upper infra heater: 1000 W - Number of infra heaters: 1 - Technology of producing microwaves: Standard technology (HVT) - Type of microwave distribution: Rotating plate
Control	<ul style="list-style-type: none"> - Manual control - Input type: Button
Heating types	 <ul style="list-style-type: none"> - Combined heating: Microwaves + grill
Features	
Safety	<ul style="list-style-type: none"> - Door safety bolt
Equipment	<ul style="list-style-type: none"> - Rotating glass plate - Rotating grid
Technical data	<ul style="list-style-type: none"> - Dimensions (W×H×D): 59,5 × 38,4 × 31,9 cm - Dimensions of packed product (W×H×D): 65 × 44,1 × 40,4 cm - Niche dimensions (W×H×D): 56,7 × 38 × 43 cm - Net weight: 14,5 kg - Gross weight: 16,5 kg - Connected load 1050 W





EXPERIENCE COOKING IN STYLE

Hobs

Whether preparing a meal for yourself or cooking for the whole family, Gorenje induction hobs deliver a truly streamlined cooking experience every time. With a myriad of finely tuned features that simplify your interaction with the cooking surface, preparing meals has never been more simple, intuitive or convenient.



AreaFlex

Bigger cooking surface

Two vertical cooking zones can be connected into one, creating large cooking surface. It allows evenly cooked or grilled food in bigger pots and pans.



AutoDetect

Instantly detects pot position

Hob automatically detects the pot position after turning it on, activating just the right cooking cone, single or connected, depending on the pot size. This happens within first 10 seconds after switching on the hob or anytime later on after manually activating the function.



StepZone

Intuitive cooking

This function connects two cooking zones into one, but with different power level presets. It mimics how the old cooktops on fire worked, when you just pushed the pot out on a minimal heat, keeping your food warm while preparing something else.



Delete function

Turn off the settings with just one press

This function is especially useful when you're cooking more dishes at once. When you need to turn off either one cooking zone, or AreaFlex with IqGrill and setted timer, just press X and you are done. No more countless presses.



ChildLock Pro

Always safety first

ChildLock Pro function is made specially for families with small children. Leaving the kids in the kitchen unattended, has never been safer since this option prevents them turning on the hob. In more advanced models this function can be activated in

custom setting mode, which will automatically lock the hob at every switch-off. Otherwise you can lock the hob by pressing the symbol.



Groove

Unique intuitive control

Groove is a special and unique element which directs and naturally limits finger movement when sliding the control bar. It adds an aesthetic element to the hob and the outcome is amazingly designed hob which promotes easy, quick and more intuitive use.



StayWarm

Staying perfect for the latecomers

The StayWarm function keeps food at a constant temperature of 70°C until the time is right to serve the meal. The food retains its original flavour and temperature until it is served.



IQprogrammes

Smart and flexible

IQcook system can be used on all cooking zones for which you can select different cooking programmes with perfect time and temperature settings. From now on boiling, simmering, grilling, warming, melting and defrosting are hassle free.



IQsimmer

A cooking marathon, made incredibly easy

IQsimmer offers a simple way to prepare dishes that require longer cooking times with slow warming up or cooking at a lower, constant temperature. Ideal for cooking dishes such as goulash.



IQgrill

Perfectly grilled steak

IQgrill makes grilling thrillingly simple, even with very little or no oil. It offers four levels of doneness and prevents food from burning. A simple way to the tastiest and healthiest barbecue ever.



IQboil

No drop leaves the pan

Perfect choice for dishes that require a large amount of water such as soups and pasta. IQboil will bring the contents of the pot to the boil and then maintain the boiling temperature. You can choose between light, moderate, and heavy boil.



TimeAssist

Keeps your cooking on track

It helps you keep record on how long you are already cooking. No more keeping an eye on the watch or wondering when you'd started preparing the meal. Now you can check the time directly on the hob.



StopGo

Taking a break, anytime

The StopGo function stops the cooking and continues with the same settings after being re-activated.



PowerBoost

Cooking on fast-forward

The PowerBoost function intensifies heating, resulting in significantly less heating-up time. It takes just 5.7 minutes to boil 2l of water from 15°C to 90°C, which is half the time of regular HiLight hobs.



Recall

Reactivate your settings

This function is very helpful, when you turn off the hob unintendedly. You have 5 seconds to recall your last used settings on the hob, which becomes very handy when you're cooking more than one dish. Within 5 seconds after you accidentally turned off the hob, turn on the hob again and within next 5 seconds press StopGo function.

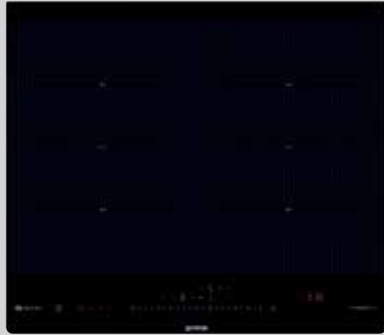

IS 646 BG Induction hob

Advanced Line

IT 642 BSC Induction hob

Essential Line

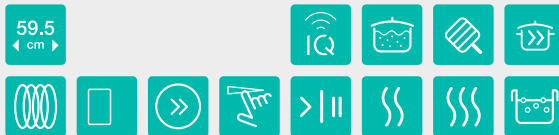

- Colour: Black
- Soft cut groove



- Colour: Black
- Soft cut hob edges

Control	<ul style="list-style-type: none"> - SliderTouch, control at your fingertips - Timer function 	<ul style="list-style-type: none"> - SmartControl - Timer function
Features	<ul style="list-style-type: none"> - BoilControl, prevents boil-overs - StopGo function - StayWarm function - SoftMelt function - PowerBoost function - AreaFlex - StepZone - TimeAssist - Recall function - EggTimer - Delete function - Personalisation - IQsimmer / IQgrill / IQboil 	<ul style="list-style-type: none"> - BoilControl, prevents boil-overs - StopGo function - StayWarm function - SoftMelt function - PowerBoost Supreme - Recall function - EggTimer - Personalisation
Cooking surface	<ul style="list-style-type: none"> - 4 induction heating zones - Left front: Ø 21×19 cm, 2,1/3 kW - Right front: Ø 21×19 cm, 2,1/3 kW - Left behind: Ø 21×19 cm, 2,1/3 kW - Right behind: Ø 21×19 cm, 2,1/3 kW 	<ul style="list-style-type: none"> - 4 induction heating zones - Left front: Ø 18 cm, 1,4/2,1 kW - Right front: Ø 16 cm, 1,4/1,85 kW - Left behind: Ø 18 cm, 1,4/2,1 kW - Right behind: Ø 21 cm, 2,3/3 kW
Safety and durability	<ul style="list-style-type: none"> - Residual heat indicator 	<ul style="list-style-type: none"> - Residual heat indicator - Safety control hob lock - ChildLock
Technical data	<ul style="list-style-type: none"> - Connected load: 7400 W - Product dimensions (W×H×D): 59,5 × 5,4 × 52 cm - Dimensions of packed product (W×H×D): 71,5 × 11 × 64 cm - Niche dimensions (W×H×D): 56-56,2 x 7 x 49 cm - Net weight: 8,9 kg - Gross weight: 9,4 kg 	<ul style="list-style-type: none"> - Connected load: 7200 W - Product dimensions (W×H×D): 59,5 × 5,4 × 52 cm - Dimensions of packed product (W×H×D): 71,5 × 11 × 64 cm - Niche dimensions (W×H×D): 56-56,2 x 7 x 49 cm - Net weight: 8,9 kg - Gross weight: 9,4 kg



IT 984 USC
Induction hob

Superior Line

ECS 959 BCSC
Glass ceramic hob

Advanced Line



- Colour: Black
- Chamfered hob edges - three times

- Colour: Black
- Chamfered front hob edge

Control	<ul style="list-style-type: none"> - SmartControl - Timer function 	<ul style="list-style-type: none"> - SliderTouch, control at your fingertips - Timer function
Features	<ul style="list-style-type: none"> - BoilControl, prevents boil-overs - StopGo function - StayWarm function - SoftMelt function - PowerBoost Supreme - Silent operation SuperSilent 	<ul style="list-style-type: none"> - BoilControl, prevents boil-overs - StopGo function - StayWarm function - FishZone
Cooking surface	<ul style="list-style-type: none"> - 5 induction heating zones - Left front: Ø 18 cm, 1,85/3 kW, - Middle front: Ø 18 cm, 1,85/3 kW, - Left behind: Ø 18 cm, 1,85/3 kW, - Middle behind: Ø 18 cm, 1,85/3 kW, - Right behind: Ø 26 cm, 2,6/3,7 kW 	<ul style="list-style-type: none"> - 5 HiLight cooking zones - Left front: Triple heating zone 12/17,5/21 cm, 0,8/1,6 kW - Right front: Ø 14,5 cm, 1,2 kW - Left behind: Ø 14,5 cm, 1,2 kW - Middle behind: Resistance heater 15,8×29 cm, 0,1 kW - Right behind: Ø 17×26,5 cm, 1,5/2,4 kW
Safety and durability	<ul style="list-style-type: none"> - Residual heat indicator - Safety control hob lock - ChildLock 	<ul style="list-style-type: none"> - Residual heat indicator - ChildLock
Technical data	<ul style="list-style-type: none"> - Connected load: 11100 W - Product dimensions (W×H×D): 90 × 5 × 51 cm - Dimensions of packed product (W×H×D): 107 × 14,5 × 61 cm - Niche dimensions (W×H×D): 85,8-86 × 6,6 × 49 cm - Net weight: 14,5 kg - Gross weight: 16,6 kg 	<ul style="list-style-type: none"> - Connected load: 7200 W - Product dimensions (W×H×D): 90 × 5,1 × 52 cm - Dimensions of packed product (W×H×D): 97 × 14,5 × 59 cm - Niche dimensions (W×H×D): 80-81 × 6,7 × 49 cm - Net weight: 11,6 kg - Gross weight: 13,3 kg

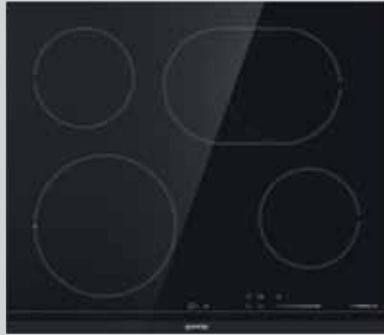

ECS 648 BCSC

Glass ceramic hob

Advanced Line

60
cm

- Colour: Black
- Chamfered front hob edge



ECS 641 BSC-LP

Glass ceramic hob

Advanced Line

59.5
cm

- Colour: Black
- Soft cut hob edges

Control	<ul style="list-style-type: none"> - SliderTouch, control at your fingertips - Timer function 	<ul style="list-style-type: none"> - SliderTouch, control at your fingertips - Timer function
Features	<ul style="list-style-type: none"> - PowerZone - BoilControl, prevents boil-overs - StopGo function - StayWarm function - FishZone 	<ul style="list-style-type: none"> - StayWarm function
Cooking surface	<ul style="list-style-type: none"> - 4 HiLight heating zones - Left front: Ø 21 cm, 2,1/3 kW - Right front: Ø 14,5 cm, 1,2 kW - Left behind: Ø 14,5 cm, 1,2 kW - Right behind: Ø 17×26,5 cm, 1,5/2,4 kW 	<ul style="list-style-type: none"> - 4 HiLight heating zones - Left front: Ø 18 cm, 1,8 kW - Right front: Ø 14 cm, 1,2 kW - Left behind: Ø 14 cm, 1,2 kW - Right behind: Ø 18 cm, 1,8 kW
Safety and durability	<ul style="list-style-type: none"> - Residual heat indicator - ChildLock 	<ul style="list-style-type: none"> - Residual heat indicator - Safety control hob lock - ChildLock
Technical data	<ul style="list-style-type: none"> - Connected load: 6900 W - Product dimensions (W×H×D): 60 × 5,5 × 52 cm - Dimensions of packed product (W×H×D): 71,5 × 14,5 × 64 cm - Niche dimensions (W×H×D): 56 × 7 × 49 cm - Net weight: 7,7 kg - Gross weight: 8,2 kg 	<ul style="list-style-type: none"> - Connected load: 3000 W - Product dimensions (W×H×D): 59,5 × 5,5 × 52 cm - Dimensions of packed product (W×H×D): 68 × 13,1 × 60 cm - Niche dimensions (W×H×D): 56 × 7 × 49 cm - Net weight: 8 kg - Gross weight: 9,3 kg



ECT 641 BSC
Glass ceramic hob

Essential Line

EC 641 BSC
Glass ceramic hob

Essential Line

59,5
cm



- Colour: Black
- Soft cut hob edges

60
cm

- Colour: Black
- Soft cut hob edges

Control	<ul style="list-style-type: none"> - Touch control - Timer function 	<ul style="list-style-type: none"> - Knob shape: Ergonomic knobs
Features	<ul style="list-style-type: none"> - BoilControl, prevents boil-overs - StopGo function - StayWarm function 	
Cooking surface	<ul style="list-style-type: none"> - 4 HiLight heating zones - Left front: Ø 21 cm, 2,3 kW - Right front: Ø 14,5 cm, 1,2 kW - Left behind: Ø 14,5 cm, 1,2 kW - Right behind: Ø 18 cm, 1,8 kW 	<ul style="list-style-type: none"> - 4 HiLight heating zones - Left front: Ø 21 cm, 2,1 kW - Right front: Ø 14,5 cm, 1,2 kW - Left behind: Ø 14,5 cm, 1,2 kW - Right behind: Ø 18 cm, 1,7 kW
Safety and durability	<ul style="list-style-type: none"> - Residual heat indicator - ChildLock 	<ul style="list-style-type: none"> - Residual heat indicator
Technical data	<ul style="list-style-type: none"> - Connected load: 6500 W - Product dimensions (W×H×D): 59,5 × 5,4 × 52 cm - Dimensions of packed product (W×H×D): 71,5 × 14,5 × 64 cm - Niche dimensions (W×H×D): 56 × 7 × 49 cm - Net weight: 7,7 kg - Gross weight: 8,2 kg 	<ul style="list-style-type: none"> - Connected load: 6200 W - Product dimensions (W×H×D): 60 × 9 × 52 cm - Dimensions of packed product (W×H×D): 71,5 × 14,5 × 64 cm - Niche dimensions (W×H×D): 56 × 7 × 49 cm - Net weight: 7,7 kg - Gross weight: 8,2 kg



E 6N1 AX

Electric hob

Essential Line

58
cm

- Colour: Stainless steel

Control

- Knob shape: Ergonomic knobs

Cooking surface

- 4 electric fast hotplates
- Left front: Ø 14,5 cm, 1,5 kW,
- Right front: Ø 14,5 cm, 1,5 kW,
- Left behind: Ø 18 cm, 2 kW,
- Right behind: Ø 18 cm, 2 kW

Technical data

- Connected load: **7000 W**
- Product dimensions (W×H×D): **58 × 7,6 × 51 cm**
- Dimensions of packed product (W×H×D): **64 × 16 × 57 cm**
- Niche dimensions (W×H×D): **56 × 6,8 × 49 cm**
- Net weight: **10 kg**
- Gross weight: **10,5 kg**

PERFECT TASTE WITH SPARK OF CREATIVITY

Gas Hobs

Cooking like a chef can be simple. All it takes is a creative spark as Gorenje gas hob will take care of everything else. With its big surface, powerful burners and advanced features, it offers

support for your wildest cooking endeavours. Ignite your inspiration and surprise your loved ones with perfect home-made dishes.





ChefBurners

More powerful and efficient cooking

New high-efficiency ChefBurners provide more efficient gas consumption and enable faster and eco-friendlier cooking. Different sizes of burners give you full flexibility, while their user-friendly positioning enables easy and safe cooking.



BigSurface

Plenty of space for every pan or pot

Enlarged cooking surface (up to 20%) and longer distances between burners offer plenty of space for all sizes of pans and pots. Sleek and flat design allows easy sliding and using very big pots without disturbance, with perfect stability for all your cooking adventures.



WokBurner

Powerful cooking, great authentic taste

New wok burner with special shape of gas crown directs flame directly to wok and enables even more powerful cooking with up to 4.0 kW power. Asian cuisine, vegetables and other dishes have never been so crisp and delicious, yet done so quickly.



Cast iron ProGrids

Strong, stable and durable support

Massive and elegant cast iron ProGrids are extremely stable and resistant even to the highest temperatures. They bring superior stability, durability and user-friendly design to your kitchen.



XtraSurface

Effortlessly shiny

Special brushment of inox enables less scratches and fingerprints on the hob surface. At the same time flat and modern design of the driptray makes it quick and easy to clean and maintain.



One-hand ignition

Simple and convenient

One-hand burner ignition brings extra comfort and easy control to your gas hob. To activate the gas burner simply press the knob down and rotate it to desired level with one hand while your other hand is free. Quick, simple, and efficient.



GasStop

Full stop, full safety

If during cooking the flame gets extinguished for any reason (wind, liquid spillage), there is no need to worry. Automatic GasStop flame failure device will cut off the gas supply immediately to ensure full safety.



 **Wok Cradle**
For really authentic results

Massive and stable wok cradle fits perfectly to the grid and offers safe and convenient use of the wok for best cooking results.



 **Coffee Reducer**
Made for perfect morning rituals

Small diameter grid enables using even the smallest pots safely and comfortably. Just right for making that perfect cup of coffee for one.



Knobs - design and ergonomoy
Perfect grip

Gas hob knobs are ergonomically designed and user-friendly, with big and well visible pointers. Sophisticated materials offer perfect grip. Innovative construction of the hob ensures optimal placement of the knobs for easy handling while keeping the area around them safe and cool.



Gas on glass

Beautiful and effective

The range of Gorenje gas hobs also includes a selection of glass hobs. Besides giving you a professional chef's control, they also bring extra advantage of easy cleaning and an appealing design. Glass hobs featuring four gas burners are available in black and

white, with standard or 'diamond' placement of burners. Cast iron pan supports are extremely stable and highly temperature resistant. Optimal cooking performance is guaranteed; and with the smooth, sheer surface, cleaning is simplicity itself.



Flush installation

Sleek and elegant

The new generation of gas hobs enables flush mount installation, which means smooth transition between the hob and the worktop. It is easier to clean and brings a modern, stylish look to your kitchen.

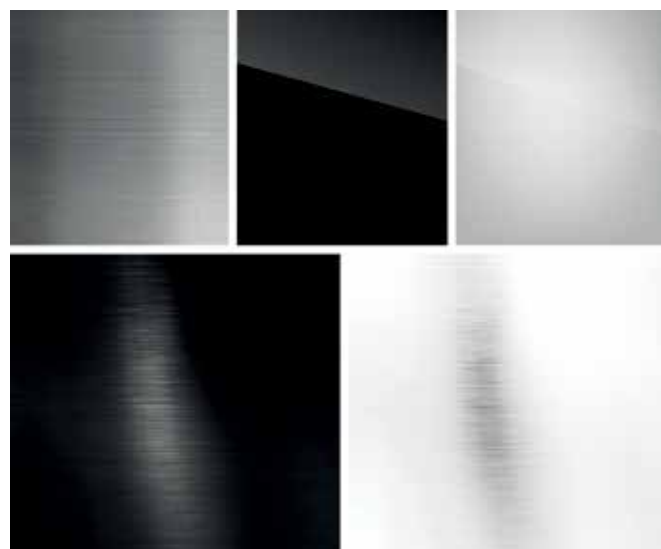

Variety of options

For all tastes

For different desires and needs new gas hobs are available in various dimensions, colours and materials, including stainless steel, tempered glass and glass-ceramic hobs. The new gas hobs also feature improved materials, which makes them more scratch-resistant, easier to clean and extends their lifetime.



GCW 961 UB
Gas on glass ceramic



- Colour: Black



GW 961 UX
Gas hob

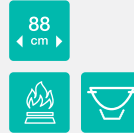

- Colour: Stainless steel

Control	- Knob shape: Ergonomic knobs	- Knob shape: Ergonomic knobs
Features	- High efficiency burners - Wok triple burner	- High efficiency burners - Wok triple burner
Cooking surface	- One-hand ignition device for hob - 1 auxiliary burner + 1 large burner + 2 standard burners + 1 wok burner - Left front: Ø 13,44 cm, 3,8 kW, - Middle front: Ø 4,3 cm, 1 kW, - Right front: Ø 6,7 cm, 1,75 kW, - Middle behind: Ø 6,7 cm, 1,75 kW, - Right behind: Ø 9,7 cm, 3 kW - Type of pan support: Cast iron grid	- One-hand ignition device for hob - 1 auxiliary burner + 1 large burner + 2 standard burners + 1 wok burner - Left front: Ø 13,44 cm, 3,8 kW, - Middle front: Ø 4,3 cm, 1 kW, - Right front: Ø 6,7 cm, 1,75 kW, - Middle behind: Ø 6,7 cm, 1,75 kW, - Right behind: Ø 9,7 cm, 3 kW - Type of pan support: Cast iron grid
Safety and durability	- Safety function - Gas control	- Safety function - Gas control
Technical data	- Gas type: G30/30 - Dimensions (W×H×D): 88 × 11,2 × 51 cm - Dimensions of packed product (W×H×D): 98 × 18 × 60 cm - Niche dimensions (W×H×D): 86 × 7,3 × 48 cm - Net weight: 20 kg - Gross weight: 22,5 kg	- Gas type: G30/30 - Dimensions (W×H×D): 88 × 10,3 × 51 cm - Dimensions of packed product (W×H×D): 98 × 18 × 60 cm - Niche dimensions (W×H×D): 86 × 7,9 × 48 cm - Net weight: 16,5 kg - Gross weight: 18,8 kg



GW 951 UX
Gas hob

88
cm



- Colour: Stainless steel



GW 961 UXB
Gas hob

88
cm



- Colour: Black

Control	- Knob shape: Ergonomic knobs	- Knob shape: Ergonomic knobs
Features	- High efficiency burners - Wok triple burner	- High efficiency burners - Wok triple burner
Cooking surface	- One-hand ignition device for hob - 1 auxiliary burner + 1 large burner + 2 standard burners + 1 wok burner - Left front: Ø 4,3 cm, 1 kW, - Right front: Ø 6,7 cm, 1,75 kW, - Left behind: Ø 6,7 cm, 1,75 kW, - Right behind: Ø 9,7 cm, 3 kW, - Center: Ø 13,44 cm, 3,8 kW - Type of pan support: Cast iron grid	- One-hand ignition device for hob - 1 auxiliary burner + 1 large burner + 2 standard burners + 1 wok burner - Left front: Ø 13,44 cm, 3,8 kW, - Middle front: Ø 4,3 cm, 1 kW, - Right front: Ø 6,7 cm, 1,75 kW, - Middle behind: Ø 6,7 cm, 1,75 kW, - Right behind: Ø 9,7 cm, 3 kW - Type of pan support: Cast iron grid
Safety and durability	- Safety function - Gas control	- Safety function - Gas control
Technical data	- Gas type: G30/30 - Dimensions (W×H×D): 88 × 10,3 × 51 cm - Dimensions of packed product (W×H×D): 98 × 18 × 60 cm - Niche dimensions (W×H×D): 86 × 7,9 × 48 cm - Net weight: 16,5 kg - Gross weight: 18,8 kg	- Gas type: G30/30 - Dimensions (W×H×D): 88 × 10,3 × 51 cm - Dimensions of packed product (W×H×D): 98 × 18 × 60 cm - Niche dimensions (W×H×D): 86 × 7,9 × 48 cm - Net weight: 20 kg - Gross weight: 22,5 kg



GW 761 UX

Gas hob



- Colour: Stainless steel

Control

- Knob shape: Ergonomic knobs

Features

- High efficiency burners
- Wok triple burner

Cooking surface

- One-hand ignition device for hob
- 1 auxiliary burner + 1 large burner + 2 standard burners + 1 wok burner
- Left front: Ø 13,44 cm, 3,8 kW,
- Middle front: Ø 4,3 cm, 1 kW,
- Right front: Ø 6,7 cm, 1,75 kW,
- Middle behind: Ø 6,7 cm, 1,75 kW,
- Right behind: Ø 9,7 cm, 3 kW
- Type of pan support: Cast iron grid

Safety and durability

- Safety function
- Gas control

Technical data

- Gas type: **G20/20 natural gas**
- Dimensions (W×H×D): **75 × 10,3 × 51 cm**
- Dimensions of packed product (W×H×D): **76 × 13 × 60 cm**
- Niche dimensions (W×H×D): **72 × 7,9 × 48 cm**
- Net weight: **13,3 kg**
- Gross weight: **15,3 kg**

GW 760 UX

Gas hob

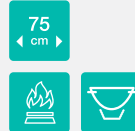

- Colour: Stainless steel

- Knob shape: Ergonomic knobs

- High efficiency burners
- Wok triple burner

- One-hand ignition device for hob
- 1 auxiliary burner + 1 large burner + 2 standard burners + 1 wok burner
- Left front: Ø 13,44 cm, 3,8 kW,
- Middle front: Ø 4,3 cm, 1 kW,
- Right front: Ø 6,7 cm, 1,75 kW,
- Middle behind: Ø 6,7 cm, 1,75 kW,
- Right behind: Ø 9,7 cm, 3 kW
- Type of pan support: Cast iron grid

- Safety function
- Gas control

- Gas type: **G20/20 natural gas**
- Dimensions (W×H×D): **75 × 10,3 × 51 cm**
- Dimensions of packed product (W×H×D): **90 × 13 × 60 cm**
- Niche dimensions (W×H×D): **72 × 7,9 × 48 cm**
- Net weight: **10,9 kg**
- Gross weight: **12,9 kg**



GW 641 X Gas hob

Essential Line

GW 641 MB Gas hob

Essential Line

60
cm



- Colour: Stainless steel

60
cm



- Colour: Black

Control	- Knob shape: Ergonomic knobs	- Knob shape: Ergonomic knobs
Features	- High efficiency burners - Wok double burner - Wok cradle	- High efficiency burners - Wok double burner - Wok cradle
Cooking surface	- One-hand ignition device for hob - 1 auxiliary burner + 1 double burner + 2 standard burners - Left front: Ø 12,3 cm, 4,05 kW, - Right front: Ø 5,37 cm, 1 kW, - Left behind: Ø 7,35 cm, 1,8 kW, - Right behind: Ø 7,35 cm, 1,8 kW - Type of pan support: Cast iron grid - Pan support cross	- One-hand ignition device for hob - 1 auxiliary burner + 1 double burner + 2 standard burners - Left front: Ø 12,3 cm, 3,5 kW, - Right front: Ø 5,37 cm, 1 kW, - Left behind: Ø 7,35 cm, 1,8 kW, - Right behind: Ø 7,35 cm, 1,8 kW - Wok double burner - Type of pan support: Cast iron grid - Pan support cross
Safety and durability	- Gas control	- Gas control
Technical data	- Gas type: G20/20 natural gas - Dimensions (W×H×D): 60 × 13 × 52 cm - Dimensions of packed product (W×H×D): 68 × 15,7 × 60 cm - Niche dimensions (W×H×D): 56 × 10 × 49 cm - Net weight: 11,9 kg - Gross weight: 12,5 kg	- Gas type: G20/20 natural gas - Dimensions (W×H×D): 60 × 13 × 52 cm - Dimensions of packed product (W×H×D): 68 × 15,7 × 60 cm - Niche dimensions (W×H×D): 56 × 10 × 49 cm - Net weight: 11,2 kg - Gross weight: 11,8 kg



G 641 X Gas hob

Essential Line

G 640 X Gas hob

Essential Line

60
cm



- Colour: Stainless steel

60
cm



- Colour: Stainless steel

Control

- Knob shape: Ergonomic knobs

- Knob shape: Ergonomic knobs

Features

- High efficiency burners

- High efficiency burners

Cooking surface

- One-hand ignition device for hob
 - 1 auxiliary burner + 1 large burner + 2 standard burners
 - Left front: Ø 9,85 cm, 3 kW,
 - Right front: Ø 5,37 cm, 1 kW,
 - Left behind: Ø 7,35 cm, 1,8 kW,
 - Right behind: Ø 7,35 cm, 1,8 kW
 - Type of pan support: Cast iron grid
 - Pan support cross

- One-hand ignition device for hob
 - 1 auxiliary burner + 1 large burner + 2 standard burners
 - Left front: Ø 9,85 cm, 3 kW,
 - Right front: Ø 5,37 cm, 1 kW,
 - Left behind: Ø 7,35 cm, 1,8 kW,
 - Right behind: Ø 7,35 cm, 1,8 kW
 - Type of pan support: Enameled
 - Pan support cross

Safety and durability

- Gas control

- Gas control

Technical data

- Gas type: **G20/20 natural gas**
 - Dimensions (W×H×D): **60 × 13 × 52 cm**
 - Dimensions of packed product (W×H×D): **68 × 15,7 × 60 cm**
 - Niche dimensions (W×H×D): **56 × 10 × 49 cm**
 - Net weight: **10,8 kg**
 - Gross weight: **11,4 kg**

- Gas type: **G20/20 natural gas**
 - Dimensions (W×H×D): **60 × 13 × 52 cm**
 - Dimensions of packed product (W×H×D): **68 × 15,7 × 60 cm**
 - Niche dimensions (W×H×D): **56 × 10 × 49 cm**
 - Net weight: **9 kg**
 - Gross weight: **9,6 kg**



G 6D41 X

Gas hob

Advanced Line



- Colour: Stainless steel

Control	- Knob shape: Ergonomic knobs
Features	- High efficiency burners
Cooking surface	<ul style="list-style-type: none"> - One-hand ignition device for hob - 1 auxiliary burner + 1 large burner + 2 standard burners - Middle front: Ø 7,35 cm, 1,9 kW, - Middle behind: Ø 5,37 cm, 1 kW, - Middle left: Ø 9,85 cm, 3 kW, - Middle right: Ø 7,35 cm, 1,9 kW - Type of pan support: Cast iron grid - Pan support cross
Safety and durability	- Gas control
Technical data	<ul style="list-style-type: none"> - Gas type: G20/20 natural gas - Dimensions of the product (W×H×D): 60 × 13 × 52 cm - Dimensions of packed product (W×H×D): 68 × 15,7 × 60 cm - Niche dimensions (W×H×D): 56 × 10 × 49 cm - Net weight: 14,6 kg - Gross weight: 15,2 kg



KC 631 USC Essential Line
Combined glassceramic hob with gas

59,5
← cm →

- Colour: Black
- Soft cut hob edges

Control

- Knob shape: Ergonomic knobs

Cooking surface

- One-hand ignition device for hob
- 1 auxiliary burner + 1 large burner + 1 standard burner + 1 HiLight heating zone
- Left front: Ø 9 cm, 3 kW,
- Right front: Ø 5 cm, 1 kW,
- Left behind: Ø 6 cm, 1,75 kW,
- Right behind: Ø 18 cm, 1,8 kW
- Type of pan support: Cast iron grid

Safety and durability

- Residual heat indicator
- Gas control

Technical data

- Connected load: **1800 W**
- Gas type: **G30/30**
- Dimensions (W×H×D): **59,5 × 10,5 × 51 cm**
- Dimensions of packed product (W×H×D): **67 × 19 × 63 cm**
- Niche dimensions (W×H×D): **56 × 10,1 × 49 cm**
- Net weight: **11,7 kg**
- Gross weight: **13,9 kg**



KC 621 USC Advanced Line
Combined glassceramic hob with gas

59,5
← cm →

- Colour: Black
- Soft cut hob edges

- Knob shape: Ergonomic knobs

- One-hand ignition device for hob
- 1 auxiliary burner + 1 large burner + 2 HiLight heating zones
- Left front: Ø 9 cm, 3 kW,
- Right front: Ø 14,5 cm, 1,2 kW,
- Left behind: Ø 5 cm, 1 kW,
- Right behind: Ø 18 cm, 1,8 kW
- Type of pan support: Cast iron grid

- Residual heat indicator
- Gas control

- Connected load: **3000 W**
- Gas type: **G30/30**
- Dimensions (W×H×D): **59,5 × 10,5 × 51 cm**
- Dimensions of packed product (W×H×D): **67 × 19 × 63 cm**
- Niche dimensions (W×H×D): **56 × 10,1 × 49 cm**
- Net weight: **9,6 kg**
- Gross weight: **11,8 kg**



K 6N30 IX

Combined cooking hob

Essential Line

58
cm



- Colour: Polished aluminium

Control	- Knob shape: Ergonomic knobs
Cooking surface	<ul style="list-style-type: none"> - One-hand ignition device for hob - 1 auxiliary burner + 1 large burner + 1 standard burner + 1 electric fast hotplate - Left front: Ø 6,9 cm, 1,9 kW, - Right front: Ø 4,6 cm, 1 kW, - Left behind: Ø 14,5 cm, 1,5 kW, - Right behind: Ø 9,4 cm, 3 kW - Type of pan support: Enameled
Safety and durability	- Gas control
Technical data	<ul style="list-style-type: none"> - Connected load: 1500 W - Gas type: G30/30 - Dimensions (W×H×D): 58 × 10,9 × 51 cm - Dimensions of packed product (W×H×D): 64 × 16 × 57 cm - Niche dimensions (W×H×D) (min-max): 55,8-56 × 10 × 49 cm - Net weight: 9,8 kg - Gross weight: 10,3 kg



ECT 321 BCSC

Glass ceramic hob

Essential Line

30
cm



- Colour: Black
- Chamfered front hob edge



EC 321 BCSC

Glass ceramic hob

Essential Line

30
cm



- Colour: Black
- Chamfered front hob edge

Control	<ul style="list-style-type: none"> - Touch control - Timer function 	<ul style="list-style-type: none"> - Knob shape: Ergonomic knobs
Features	<ul style="list-style-type: none"> - BoilControl, prevents boil-overs - Pause function - StayWarm function 	<ul style="list-style-type: none"> - 2 HiLight heating zones - Front: Ø 18 cm, 1,7 kW, - Behind: Ø 14,5 cm, 1,2 kW
Cooking surface	<ul style="list-style-type: none"> - 2 HiLight heating zones - Front: Ø 18 cm, 1,8 kW, - Behind: Ø 14,5 cm, 1,2 kW 	
Safety and durability	<ul style="list-style-type: none"> - Residual heat indicator - ChildLock 	<ul style="list-style-type: none"> - Residual heat indicator
Technical data	<ul style="list-style-type: none"> - Connected load: 3000 W - Product dimensions (W×H×D): 30 × 5,1 × 52 cm - Dimensions of packed product (W×H×D): 44,5 × 16 × 61 cm - Niche dimensions (W×H×D): 28,3 × 6,7 × 49 cm - Net weight: 4,1 kg - Gross weight: 4,6 kg 	<ul style="list-style-type: none"> - Connected load: 2900 W - Product dimensions (W×H×D): 30 × 8,5 × 52 cm - Dimensions of packed product (W×H×D): 44,5 × 16 × 61 cm - Niche dimensions (W×H×D): 28,3 × 6,7 × 49 cm - Net weight: 4,1 kg - Gross weight: 4,6 kg



EM 300 E

Electric hob

28,8
cm

- Colour: Stainless steel

Control	- Knob shape: Ergonomic knobs
Cooking surface	- 1 standard hotplate + 1 fast hotplate - Front: Ø 14,5 cm, 1 kW, - Behind: Ø 18 cm, 2 kW
Technical data	- Connected load: 3000 W - Dimensions (W×H×D): 28,8 × 7,5 × 51 cm - Dimensions of packed product (W×H×D): 34 x 12 x 58 cm - Niche dimensions (W×H×D): 26,8 × 5,7 × 49 cm - Net weight: 5,3 kg - Gross weight: 5,6 kg

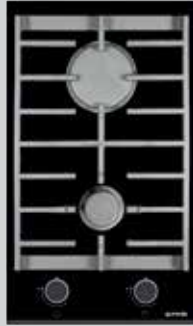

GC 341 UC
Gas on glass ceramic

30
cm

- Colour: Black
- Chamfered front hob edge



G 340 UX
Gas hob

28.8
cm



- Colour: Stainless steel

Control	- Knob shape: Ergonomic knobs	- Knob shape: Ergonomic knobs
Features		- High efficiency burners
Cooking surface	<ul style="list-style-type: none"> - One-hand ignition device for hob - 1 auxiliary burner + 1 large burner - Front: Ø 5,5 cm, 1 kW, - Behind: Ø 10 cm, 3 kW - Type of pan support: Cast iron grid 	<ul style="list-style-type: none"> - Single-handed ignition device - 1 auxiliary burner + 1 large burner - Front: Ø 4,3 cm, 1 kW, - Behind: Ø 9,7 cm, 3 kW - Type of pan support: Enameled
Safety and durability	- Gas control	<ul style="list-style-type: none"> - Safety function - Gas control
Technical data	<ul style="list-style-type: none"> - Gas type: G20/20 natural gas - Dimensions (W×H×D): 30 × 10,3 × 51 cm - Dimensions of packed product (W×H×D): 44,5 × 17 × 61 cm - Niche dimensions (W×H×D): 27,5 × 10,2 × 49 cm - Net weight: 6,6 kg - Gross weight: 7,1 kg 	<ul style="list-style-type: none"> - Gas type: G20/20 natural gas - Dimensions of the product (W×H×D): 28,8 × 10,3 × 51 cm - Dimensions of packed product (W×H×D): 37 × 14 × 56 cm - Niche dimensions (W×H×D): 27 × 7,9 × 48 cm - Net weight: 4,3 kg - Gross weight: 5 kg



BBQ 2400 X

Barbecue grill

BDF 34 X

Deep fryer

28,8
← cm →

28,8
← cm →

- Colour: Stainless steel

- Colour: Stainless steel

Control

- Knob shape: Ergonomic knobs

- Knob shape: Ergonomic knobs

Cooking surface

- Wire grilling rack
- Lava stone container

- Handle and Lid
- Frying basket

Safety and durability

- Safety function

Technical data

- Connected load: **2400 W**
- Dimensions of the product (W×H×D): **28,8 × 13,6 × 51 cm**
- Dimensions of packed product (W×H×D): **34,5 × 17,5 × 57 cm**
- Niche dimensions (W×H×D): **27 × 12,2 × 49 cm**
- Net weight: **8 kg**
- Gross weight: **8,8 kg**

- Connected load: **2300 W**
- Dimensions of the product (W×H×D): **28,8 × 21,2 × 51 cm**
- Dimensions of packed product (W×H×D): **34,5 × 26,5 × 57 cm**
- Niche dimensions (W×H×D): **27 × 20,4 × 49 cm**
- Net weight: **7,7 kg**
- Gross weight: **8,6 kg**

A HELPING HAND FROM ABOVE

Hoods

Gorenje hoods bring two in one as they are technologically advanced tools in the form of superbly designed objects. They are a perfect companion to a modern lifestyle – they contribute to a healthier living environment, efficiently remove bad smells and work silently and reliably. Gorenje hoods are made of top quality materials and offer the best user experience whilst cooking, cleaning or simply just watching them.







AdaptAir

No smell. Just air.

Patented AdaptAir technology ensures completely even air suction over the entire hood surface. Steam, smells and impurities no longer enter the kitchen air.



Polyurethane filter

Benefits of polyurethane foam

Unique AdaptAir and aluminium grease filters are enhanced with a special polyurethane foam that eliminates up to 98% of all grease particles and other impurities. At the same time, the hood maintains its absorption efficiency.



LED light

See what you're cooking

LED lighting provides excellent and highly efficient illumination of the cooking hob and represents an important aesthetic and functional element in the kitchen. Its useful life is thirty times as long as that of conventional light bulbs, and it saves up to ten times as much power.

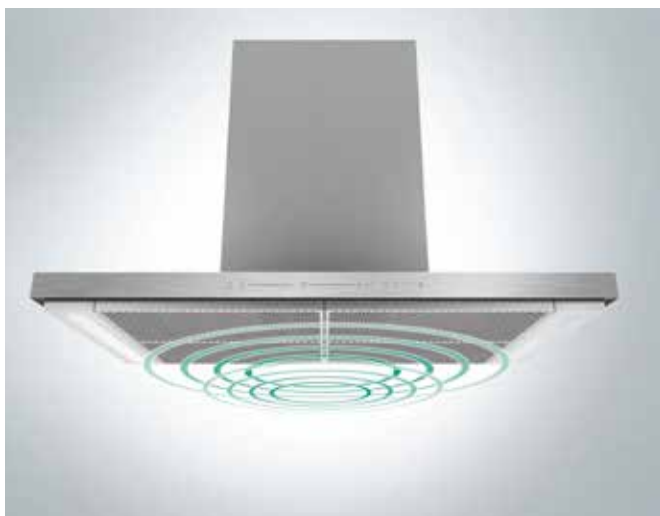

AdaptTech Automatic fan operation

A special sensor, when in automatic operating mode, senses the level of impurities or steam, humidity and gases and responds suitably. It automatically adjusts the fan speed accordingly or, when it is no longer needed, even completely stops the fan.

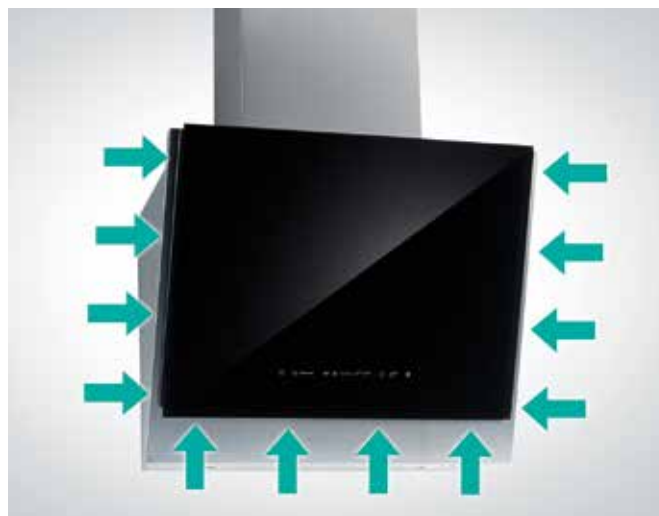

P.A.S. System Smart, targeted extraction with less noise

Innovative perimetric aspiration system (P.A.S.) directs its extraction power to the edges. This approach reduces energy consumption and noise at the same time. As a result air extraction is considerably more silent and efficient.



TouchFree coating Shiney and fingerprint-free finish

All stainless steel surfaces are coated with a special TouchFree film that prevents fingerprint markings, leaving the surface always shiny and making cleaning much easier.



Timer and refresh Always fresh and punctual

Special advantages of new Gorenje hoods include setting the timing for automatic switching off and the refresh function which is activated every hour, refreshing the air for 10 minutes.

Advantages of new hoods with smart glass design

New Gorenje hoods with smart glass design bring great visual appeal to your kitchen, along with many advantages. High quality glass is easy to clean and at the same time offers an additional space for spices or small objects on the sides.



SmartCurve Better capturing steam and grease

New models of Gorenje hoods feature new innovative shape with specially curved glass which captures more steam, grease and odours as standard design hoods.



Controls

Cleverly placed above the glass surface, the controls of the hood are protected from grease and stay clean and perfectly operating for a long time. They are easy to reach and use (no bending below the hood cap), simple to clean and stay cold during the cooking.



LED-lights

Smart design and placement behind the glass surface, the LED-lights stay protected from grease and therefore require no cleaning. Simply wiping the glass below them will do the trick.



Polyurethane grease filter

These models of hoods use one big polyurethane filter which is easy to install and replace with just a simple click.



IHGC 933 E16X
Island cooker hood

Essential Line

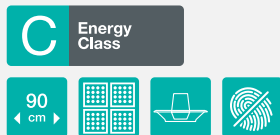

- Venting with air extraction or recirculation
- Material of housing/chimney: Stainless steel and glass / Stainless steel
- Colour of housing/chimney: Glass and stainless steel / Stainless steel



IHT 963 S2X
Island cooker hood

Superior Line



- Venting with air extraction or recirculation
- Material of housing/chimney: Stainless steel / Stainless steel
- Colour of housing/chimney: Stainless steel / Stainless steel

Efficiency	<ul style="list-style-type: none"> - Maximum extraction rate by extraction operation: 462 m³/h - Maximum extraction rate by recirculation operation: 392 m³/h - Venting tube diameter: 15 cm 	<ul style="list-style-type: none"> - Maximum extraction rate by extraction operation: 570 m³/h - Maximum extraction rate by recirculation operation: 420 m³/h - Venting tube diameter: 15 cm
The capacity of ventilator	<ul style="list-style-type: none"> - Air flow by extraction version, step 1: 195 m³/h - Air flow by extraction version, step 2: 331 m³/h - Air flow by extraction version, step 3: 462 m³/h 	<ul style="list-style-type: none"> - Air flow by extraction version, step 1: 300 m³/h - Air flow by extraction version, step 2: 370 m³/h - Air flow by extraction version, step 3: 570 m³/h - Airflow boost position (PowerBoost 1) - extraction: 675 m³/h - Airflow boost position (PowerBoost 2) - extraction: 775 m³/h - Number of PowerBoost functions: 2
Control	<ul style="list-style-type: none"> - Electronic control - Control setting: Button control - Number of speed positions: 3 	<ul style="list-style-type: none"> - AdaptTech: Automatic fan operation - Electronic control - Control setting: Touch control on metal - Timer function - Number of speed positions: 3
Features	<ul style="list-style-type: none"> - TouchFree Inox - SmartCurve - Lamp type: LED - On/off light switch - Number of lights: 4 - Total power of lights: 12 W 	<ul style="list-style-type: none"> - TouchFree Inox - Constant ventilation ReFresh - Lamp type: Led strip - Dimmer function - Number of lights: 2 - Total power of lights: 15 W
Equipment	<ul style="list-style-type: none"> - Filter material: Washable aluminium with polyurethane foam - Number of motors: 1 - Motor type: Capacitor motor - No return airflow flap: 150 mm 	<ul style="list-style-type: none"> - Filter material: Washable stainless steel with polyurethane foam and flaps - Highly efficient filter: AdaptAir Pro - Grease filter indicator - Number of motors: 1 - Motor type: Capacitor motor - No return airflow flap: 150 mm
Technical data	<ul style="list-style-type: none"> - Noise level (max.): 59 dB(A)re 1 pW - Min. height of the chimney: 285 mm - Max. height of the chimney: 510 mm - Annual energy consumption: 59,4 kWh - Dimensions (W×H×D): 90 × 60,5 × 60 cm - Dimensions of packed product (W×H×D): 109 × 87 × 71,5 cm - Net weight: 28,1 kg - Gross weight: 36,3 kg - Connected load: 147 W 	<ul style="list-style-type: none"> - Noise level (max.): 68 dB(A)re 1 pW - Min. height of the chimney: 720 mm - Max. height of the chimney: 1020 mm - Annual energy consumption: 56,8 kWh - Dimensions (W×H×D): 89,8 × 6 × 60 cm - Dimensions of packed product (W×H×D): 101,5 × 80 × 58,4 cm - Net weight: 27,8 kg - Gross weight: 35,2 kg - Connected load: 293 W



IDQ 4545 X
Island cooker hood



- Venting with air extraction or recirculation
- Material of housing/chimney: Stainless steel / Stainless steel
- Colour of housing/chimney: Stainless steel / Stainless steel



IDR 4545 E
Island cooker hood



- Venting with air extraction or recirculation
- Material of housing/chimney: Stainless steel / Stainless steel
- Colour of housing/chimney: Stainless steel / Stainless steel

Efficiency	<ul style="list-style-type: none"> - Maximum extraction rate by extraction operation: 558 m³/h - Maximum extraction rate by recirculation operation: 410 m³/h - Venting tube diameter: 15 cm 	<ul style="list-style-type: none"> - Maximum extraction rate by extraction operation: 576 m³/h - Maximum extraction rate by recirculation operation: 408 m³/h - Venting tube diameter: 15 cm
The capacity of ventilator	<ul style="list-style-type: none"> - Air flow by extraction version, step 1: 185 m³/h - Air flow by extraction version, step 3: 386 m³/h - Air flow by extraction version, step 4: 558 m³/h 	<ul style="list-style-type: none"> - Air flow by extraction version, step 1: 218 m³/h - Air flow by extraction version, step 3: 384 m³/h - Air flow by extraction version, step 4: 576 m³/h
Control	<ul style="list-style-type: none"> - Electronic control - Control setting: Touch control - Timer function - Number of speed positions: 4 	<ul style="list-style-type: none"> - Electronic control - Control setting: Touch control - Timer function - Number of speed positions: 4
Features	<ul style="list-style-type: none"> - Lamp type: LED - On/off light switch - Number of lights: 4 - Total power of lights: 32 W - Perimetric suction 	<ul style="list-style-type: none"> - Lamp type: LED - On/off light switch - Number of lights: 4 - Total power of lights: 80 W - Perimetric suction
Equipment	<ul style="list-style-type: none"> - Filter material: Aluminium - Washable grease filter - Number of motors: 1 - No return airflow flap: 150 mm 	<ul style="list-style-type: none"> - Filter material: Aluminium - Washable grease filter - Number of motors: 1 - No return airflow flap: 150 mm
Technical data	<ul style="list-style-type: none"> - Noise level (max.): 59 dB(A)re 1 pW - Min. height of the chimney: 865 mm - Max. height of the chimney: 1165 mm - Annual energy consumption: 123,2 kWh - Dimensions (W×H×D): 40 × 86,5 × 30 cm - Dimensions of packed product (W×H×D): 76 × 52 × 88 cm - Net weight: 22 kg - Gross weight: 28 kg - Connected load: 290 W 	<ul style="list-style-type: none"> - Noise level (max.): 67 dB(A)re 1 pW - Min. height of the chimney: 900 mm - Max. height of the chimney: 1200 mm - Annual energy consumption: 175,6 kWh - Dimensions (W×H×D): 39 × 90 × 39 cm - Dimensions of packed product (W×H×D): 91 × 49 × 88 cm - Net weight: 22,1 kg - Gross weight: 28 kg - Connected load: 230 W



WHI 943 A3XGB
Wall mounted cooker hood

Advanced Line

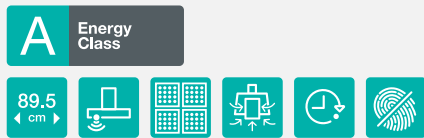

- Venting with air extraction or recirculation
- Material of housing/chimney: Stainless steel and glass / Stainless steel
- Colour of housing/chimney: Stainless steel and black glass / Stainless steel



WHI 943 E6XGB
Wall mounted cooker hood

Essential Line



- Venting with air extraction or recirculation
- Material of housing/chimney: Stainless steel and glass / Stainless steel
- Colour of housing/chimney: Stainless steel and black glass / Stainless steel

Efficiency	<ul style="list-style-type: none"> - Maximum extraction rate by extraction operation: 560 m³/h - Maximum extraction rate by recirculation operation: 420 m³/h - Venting tube diameter: 15 cm 	<ul style="list-style-type: none"> - Maximum extraction rate by extraction operation: 650 m³/h - Maximum extraction rate by recirculation operation: 488 m³/h - Venting tube diameter: 15 cm
The capacity of ventilator	<ul style="list-style-type: none"> - Air flow by extraction version, step 1: 302 m³/h - Air flow by extraction version, step 2: 385 m³/h - Air flow by extraction version, step 3: 560 m³/h - Airflow boost position (PowerBoost 2) - recirculation: 600 m³/h - Airflow boost position (PowerBoost 1) - extraction: 685 m³/h - Airflow boost position (PowerBoost 2) - extraction: 800 m³/h - Number of PowerBoost functions: 2 	<ul style="list-style-type: none"> - Air flow by extraction version, step 1: 245 m³/h - Air flow by extraction version, step 2: 360 m³/h - Air flow by extraction version, step 3: 650 m³/h
Control	<ul style="list-style-type: none"> - AdaptTech: Automatic fan operation - Electronic control - Control setting: Touch control - Timer function - Number of speed positions: 3 	<ul style="list-style-type: none"> - Electronic control - Control setting: Touch control - Number of speed positions: 3
Features	<ul style="list-style-type: none"> - TouchFree Inox - Constant ventilation ReFresh - Lamp type: LED - Dimmer function - Number of lights: 2 - Total power of lights: 6 W - Perimetric suction 	<ul style="list-style-type: none"> - TouchFree Inox - Lamp type: LED - On/off light switch - Number of lights: 2 - Total power of lights: 6 W - Perimetric suction
Equipment	<ul style="list-style-type: none"> - Filter material: Washable aluminium with polyurethane foam - Grease filter indicator - Number of motors: 1 - Motor type: Capacitor motor - No return airflow flap: 150 mm 	<ul style="list-style-type: none"> - Filter material: Washable aluminium with polyurethane foam - Number of motors: 1 - No return airflow flap: 150 mm
Technical data	<ul style="list-style-type: none"> - Noise level (max.): 63 dB(A)re 1 pW - Min. height of the chimney: 650 mm - Max. height of the chimney: 980 mm - Annual energy consumption: 58,4 kWh - Dimensions (W×H×D): 89,5 × 45 × 38 cm - Dimensions of packed product (W×H×D): 93,6 × 57,4 × 49,6 cm - Net weight: 20,7 kg - Gross weight: 24,8 kg - Connected load: 284 W 	<ul style="list-style-type: none"> - Noise level (max.): 68 dB(A)re 1 pW - Min. height of the chimney: 650 mm - Max. height of the chimney: 980 mm - Annual energy consumption: 66,9 kWh - Dimensions (W×H×D): 89,5 × 45 × 38 cm - Dimensions of packed product (W×H×D): 100,5 × 52 × 56,3 cm - Net weight: 20,6 kg - Gross weight: 24,7 kg - Connected load: 266 W

**WHI 943 E6B**

Essential Line

Wall mounted cooker hood

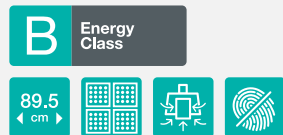

- Venting with air extraction or recirculation
- Material of housing/chimney: Varnished steel
- Colour of housing/chimney: Black painted and black glass / Black

**WHI 623 E1XGB**

Essential Line

Wall mounted cooker hood



- Venting with air extraction or recirculation
- Material of housing/chimney: Stainless steel and glass / Stainless steel
- Colour of housing/chimney: Stainless steel and black glass / Stainless steel

Efficiency	<ul style="list-style-type: none"> - Maximum extraction rate by extraction operation: 650 m³/h - Maximum extraction rate by recirculation operation: 488 m³/h - Venting tube diameter: 15 cm 	<ul style="list-style-type: none"> - Maximum extraction rate by extraction operation: 560 m³/h - Maximum extraction rate by recirculation operation: 420 m³/h - Venting tube diameter: 15 cm
The capacity of ventilator	<ul style="list-style-type: none"> - Air flow by extraction version, step 1: 245 m³/h - Air flow by extraction version, step 2: 360 m³/h - Air flow by extraction version, step 3: 650 m³/h 	<ul style="list-style-type: none"> - Air flow by extraction version, step 1: 235 m³/h - Air flow by extraction version, step 2: 360 m³/h - Air flow by extraction version, step 3: 560 m³/h
Control	<ul style="list-style-type: none"> - Electronic control - Control setting: Touch control - Number of speed positions: 3 	<ul style="list-style-type: none"> - Mechanic control - Control setting: Button control - Number of speed positions: 3
Features	<ul style="list-style-type: none"> - TouchFree Inox - Lamp type: LED - On/off light switch - Number of lights: 2 - Total power of lights: 6 W - Perimetric suction 	<ul style="list-style-type: none"> - TouchFree Inox - Lamp type: LED - On/off light switch - Number of lights: 2 - Total power of lights: 6 W - Perimetric suction
Equipment	<ul style="list-style-type: none"> - Filter material: Washable aluminium with polyurethane foam - Number of motors: 1 - No return airflow flap: 150 mm 	<ul style="list-style-type: none"> - Filter material: Washable aluminium with polyurethane foam - Number of motors: 1 - No return airflow flap: 150 mm
Technical data	<ul style="list-style-type: none"> - Noise level (max.): 68 dB(A)re 1 pW - Min. height of the chimney: 650 mm - Max. height of the chimney: 980 mm - Annual energy consumption: 66,9 kWh - Dimensions (W×H×D): 89,5 × 45 × 38 cm - Dimensions of packed product (W×H×D): 100,4 × 51,4 × 56,4 cm - Net weight: 20,6 kg - Gross weight: 24,7 kg - Connected load: 266 W 	<ul style="list-style-type: none"> - Noise level (max.): 67 dB(A)re 1 pW - Min. height of the chimney: 650 mm - Max. height of the chimney: 980 mm - Annual energy consumption: 67,1 kWh - Dimensions (W×H×D): 59,5 × 45 × 38 cm - Dimensions of packed product (W×H×D): 71 × 51,9 × 56,2 cm - Net weight: 15,5 kg - Gross weight: 18,8 kg - Connected load: 206 W



WHT 943 E4XBG
Wall mounted cooker hood

Essential Line

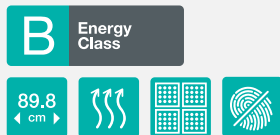

- Venting with air extraction or recirculation
- Material of housing/chimney: Stainless steel and glass / Stainless steel
- Colour of housing/chimney: Stainless steel and black glass / Stainless steel



WHT 923 E5X
Wall mounted cooker hood

Essential Line



- Venting with air extraction or recirculation
- Material of housing/chimney: Stainless steel / Stainless steel
- Colour of housing/chimney: Stainless steel / Stainless steel

Efficiency	<ul style="list-style-type: none"> - Maximum extraction rate by extraction operation: 650 m³/h - Maximum extraction rate by recirculation operation: 488 m³/h - Venting tube diameter: 15 cm 	<ul style="list-style-type: none"> - Maximum extraction rate by extraction operation: 560 m³/h - Maximum extraction rate by recirculation operation: 420 m³/h - Venting tube diameter: 15 cm
The capacity of ventilator	<ul style="list-style-type: none"> - Air flow by extraction version, step 1: 235 m³/h - Air flow by extraction version, step 2: 355 m³/h - Air flow by extraction version, step 3: 650 m³/h 	<ul style="list-style-type: none"> - Air flow by extraction version, step 1: 240 m³/h - Air flow by extraction version, step 2: 365 m³/h - Air flow by extraction version, step 3: 560 m³/h
Control	<ul style="list-style-type: none"> - Electronic control - Control setting: Touch control - Number of speed positions: 3 	<ul style="list-style-type: none"> - Mechanic control - Control setting: Button control - Number of speed positions: 3
Features	<ul style="list-style-type: none"> - TouchFree Inox - Lamp type: LED - On/off light switch - Number of lights: 2 - Total power of lights: 6 W 	<ul style="list-style-type: none"> - TouchFree Inox - Lamp type: LED - On/off light switch - Number of lights: 2 - Total power of lights: 6 W
Equipment	<ul style="list-style-type: none"> - Filter material: Washable stainless steel with polyurethane foam and flaps - Highly efficient filter: AdaptAir Pro - Number of motors: 1 - No return airflow flap: 150 mm 	<ul style="list-style-type: none"> - Filter material: Washable aluminium with polyurethane foam - Number of motors: 1 - No return airflow flap: 150 mm
Technical data	<ul style="list-style-type: none"> - Noise level (max.): 70 dB(A)re 1 pW - Min. height of the chimney: 740 mm - Max. height of the chimney: 980 mm - Annual energy consumption: 68,3 kWh - Dimensions (W×H×D): 89,8 × 6 × 45,6 cm - Dimensions of packed product (W×H×D): 100,6 × 54,1 × 49,3 cm - Net weight: 16,7 kg - Gross weight: 22,3 kg - Connected load: 266 W 	<ul style="list-style-type: none"> - Noise level (max.): 67 dB(A)re 1 pW - Min. height of the chimney: 740 mm - Max. height of the chimney: 980 mm - Annual energy consumption: 68,9 kWh - Dimensions (W×H×D): 89,8 × 4,2 × 45 cm - Dimensions of packed product (W×H×D): 101 × 53,8 × 52,4 cm - Net weight: 13,3 kg - Gross weight: 18,9 kg - Connected load: 206 W

**WHT 623 E5X**

Essential Line

Wall mounted cooker hood



- Venting with air extraction or recirculation
- Material of housing/chimney: Stainless steel / Stainless steel
- Colour of housing/chimney: Stainless steel / Stainless steel

**WHT 623 E3XBG**

Essential Line

Wall mounted cooker hood



- Venting with air extraction or recirculation
- Material of housing/chimney: Stainless steel and glass / Stainless steel
- Colour of housing/chimney: Stainless steel and black glass / Stainless steel

Efficiency	<ul style="list-style-type: none"> - Maximum extraction rate by extraction operation: 550 m³/h - Maximum extraction rate by recirculation operation: 413 m³/h - Venting tube diameter: 15 cm 	<ul style="list-style-type: none"> - Maximum extraction rate by extraction operation: 550 m³/h - Maximum extraction rate by recirculation operation: 413 m³/h - Venting tube diameter: 15 cm
The capacity of ventilator	<ul style="list-style-type: none"> - Air flow by extraction version, step 1: 245 m³/h - Air flow by extraction version, step 2: 355 m³/h - Air flow by extraction version, step 3: 550 m³/h 	<ul style="list-style-type: none"> - Air flow by extraction version, step 1: 245 m³/h - Air flow by extraction version, step 2: 355 m³/h - Air flow by extraction version, step 3: 550 m³/h
Control	<ul style="list-style-type: none"> - Mechanic control - Control setting: Button control - Number of speed positions: 3 	<ul style="list-style-type: none"> - Mechanic control - Control setting: Button control - Number of speed positions: 3
Features	<ul style="list-style-type: none"> - TouchFree Inox - Lamp type: LED - On/off light switch - Number of lights: 2 - Total power of lights: 6 W 	<ul style="list-style-type: none"> - TouchFree Inox - Lamp type: LED - On/off light switch - Number of lights: 2 - Total power of lights: 6 W
Equipment	<ul style="list-style-type: none"> - Filter material: Washable aluminium with polyurethane foam - Number of motors: 1 - No return airflow flap: 150 mm 	<ul style="list-style-type: none"> - Filter material: Washable aluminium with polyurethane foam - Number of motors: 1 - No return airflow flap: 150 mm
Technical data	<ul style="list-style-type: none"> - Noise level (max.): 68 dB(A)re 1 pW - Min. height of the chimney: 740 mm - Max. height of the chimney: 980 mm - Annual energy consumption: 69,3 kWh - Dimensions (W×H×D): 59,8 × 4,2 × 45 cm - Dimensions of packed product (W×H×D): 71,1 × 59 × 49,1 cm - Net weight: 11,6 kg - Gross weight: 16,2 kg - Connected load: 206 W 	<ul style="list-style-type: none"> - Noise level (max.): 68 dB(A)re 1 pW - Min. height of the chimney: 740 mm - Max. height of the chimney: 980 mm - Annual energy consumption: 69,3 kWh - Dimensions (W×H×D): 59,8 × 4,2 × 45,6 cm - Dimensions of packed product (W×H×D): 71,1 × 59,2 × 49 cm - Net weight: 11,9 kg - Gross weight: 16,5 kg - Connected load: 206 W



WHGC 933 E16X
Wall mounted cooker hood

Essential Line



- Venting with air extraction or recirculation
- Material of housing/chimney: Stainless steel and glass / Stainless steel
- Colour of housing/chimney: Glass and stainless steel / Stainless steel



WHGC 633 E16X
Wall mounted cooker hood

Essential Line

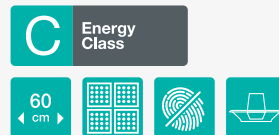

- Venting with air extraction or recirculation
- Material of housing/chimney: Stainless steel and glass / Stainless steel
- Colour of housing/chimney: Glass and stainless steel / Stainless steel

Efficiency	<ul style="list-style-type: none"> - Maximum extraction rate by extraction operation: 462 m³/h - Maximum extraction rate by recirculation operation: 392 m³/h - Venting tube diameter: 15 cm 	<ul style="list-style-type: none"> - Maximum extraction rate by extraction operation: 462 m³/h - Maximum extraction rate by recirculation operation: 392 m³/h - Venting tube diameter: 15 cm
The capacity of ventilator	<ul style="list-style-type: none"> - Air flow by extraction version, step 1: 195 m³/h - Air flow by extraction version, step 2: 331 m³/h - Air flow by extraction version, step 3: 462 m³/h 	<ul style="list-style-type: none"> - Air flow by extraction version, step 1: 195 m³/h - Air flow by extraction version, step 2: 331 m³/h - Air flow by extraction version, step 3: 462 m³/h
Control	<ul style="list-style-type: none"> - Electronic control - Control setting: Button control - Number of speed positions: 3 	<ul style="list-style-type: none"> - Electronic control - Control setting: Button control - Number of speed positions: 3
Features	<ul style="list-style-type: none"> - TouchFree Inox - SmartCurve - Lamp type: LED - On/off light switch - Number of lights: 2 - Total power of lights: 6 W 	<ul style="list-style-type: none"> - TouchFree Inox - SmartCurve - Lamp type: LED - On/off light switch - Number of lights: 2 - Total power of lights: 6 W
Equipment	<ul style="list-style-type: none"> - Filter material: Washable aluminium with polyurethane foam - Number of motors: 1 - Motor type: Capacitor motor - No return airflow flap: 150 mm 	<ul style="list-style-type: none"> - Filter material: Washable aluminium with polyurethane foam - Number of motors: 1 - Motor type: Capacitor motor - No return airflow flap: 150 mm
Technical data	<ul style="list-style-type: none"> - Noise level (max.): 59 dB(A)re 1 pW - Min. height of the chimney: 150 mm - Max. height of the chimney: 380 mm - Annual energy consumption: 55,1 kWh - Dimensions (W×H×D): 90 × 55 × 45 cm - Dimensions of packed product (W×H×D): 99 × 67,5 × 51,5 cm - Net weight: 16,9 kg - Gross weight: 21,8 kg - Connected load: 141 W 	<ul style="list-style-type: none"> - Noise level (max.): 59 dB(A)re 1 pW - Min. height of the chimney: 150 mm - Max. height of the chimney: 380 mm - Annual energy consumption: 55,1 kWh - Dimensions (W×H×D): 60 × 55 × 45 cm - Dimensions of packed product (W×H×D): 67,5 × 69 × 51,5 cm - Net weight: 15,5 kg - Gross weight: 19,5 kg - Connected load: 141 W



WHC 943 A1XGB

Wall mounted cooker hood

Advanced Line

B Energy Class



- Venting with air extraction or recirculation
- Material of housing/chimney: Stainless steel and glass / Stainless steel
- Colour of housing/chimney: Stainless steel and black glass / Stainless steel

Efficiency	<ul style="list-style-type: none"> - Maximum extraction rate by extraction operation: 451 m³/h - Venting tube diameter: 15 cm
The capacity of ventilator	<ul style="list-style-type: none"> - Air flow by extraction version, step 1: 270 m³/h - Air flow by extraction version, step 2: 360 m³/h - Air flow by extraction version, step 3: 451 m³/h - Airflow boost position (PowerBoost 1) - extraction: 737 m³/h - Number of PowerBoost functions: 1
Control	<ul style="list-style-type: none"> - AdaptTech: Automatic fan operation - Electronic control - Control setting: Touch control - Timer function - Number of speed positions: 3
Features	<ul style="list-style-type: none"> - TouchFree Inox - Constant ventilation ReFresh - Lamp type: LED - On/off light switch - Number of lights: 2 - Total power of lights: 6 W
Equipment	<ul style="list-style-type: none"> - Filter material: Washable aluminium with polyurethane foam - Grease filter indicator - Number of motors: 1 - Motor type: Capacitor motor - No return airflow flap: 150 mm
Technical data	<ul style="list-style-type: none"> - Noise level (max.): 62 dB(A)re 1 pW - Min. height of the chimney: 690 mm - Max. height of the chimney: 960 mm - Annual energy consumption: 59,1 kWh - Dimensions (W×H×D): 90 × 10 × 50,5 cm - Dimensions of packed product (W×H×D): 100 × 36 × 42 cm - Net weight: 11,5 kg - Gross weight: 16,4 kg - Connected load: 266 W



WHC 923 E16X
Wall mounted cooker hood

Essential Line



- Venting with air extraction or recirculation
- Material of housing/chimney: Stainless steel / Stainless steel
- Colour of housing/chimney: Stainless steel / Stainless steel



WHC 623 E16X
Wall mounted cooker hood

Essential Line



- Venting with air extraction or recirculation
- Material of housing/chimney: Stainless steel / Stainless steel
- Colour of housing/chimney: Stainless steel / Stainless steel

Efficiency	<ul style="list-style-type: none"> - Maximum extraction rate by extraction operation: 520 m³/h - Maximum extraction rate by recirculation operation: 390 m³/h - Venting tube diameter: 15 cm 	<ul style="list-style-type: none"> - Maximum extraction rate by extraction operation: 505 m³/h - Maximum extraction rate by recirculation operation: 380 m³/h - Venting tube diameter: 15 cm
The capacity of ventilator	<ul style="list-style-type: none"> - Air flow by extraction version, step 1: 238 m³/h - Air flow by extraction version, step 2: 380 m³/h - Air flow by extraction version, step 3: 520 m³/h 	<ul style="list-style-type: none"> - Air flow by extraction version, step 1: 230 m³/h - Air flow by extraction version, step 2: 372 m³/h - Air flow by extraction version, step 3: 505 m³/h
Control	<ul style="list-style-type: none"> - Mechanic control - Control setting: Button control - Number of speed positions: 3 	<ul style="list-style-type: none"> - Mechanic control - Control setting: Button control - Number of speed positions: 3
Features	<ul style="list-style-type: none"> - TouchFree Inox - Lamp type: LED - On/off light switch - Number of lights: 2 - Total power of lights: 6 W 	<ul style="list-style-type: none"> - TouchFree Inox - Lamp type: LED - On/off light switch - Number of lights: 2 - Total power of lights: 6 W
Equipment	<ul style="list-style-type: none"> - Filter material: Washable aluminium with polyurethane foam - Number of motors: 1 - Motor type: Capacitor motor - No return airflow flap: 150 mm 	<ul style="list-style-type: none"> - Filter material: Washable aluminium with polyurethane foam - Number of motors: 1 - Motor type: Capacitor motor - No return airflow flap: 150 mm
Technical data	<ul style="list-style-type: none"> - Noise level (max.): 63 dB(A)re 1 pW - Min. height of the chimney: 545 mm - Max. height of the chimney: 875 mm - Annual energy consumption: 60,4 kWh - Dimensions (W×H×D): 90 × 25 × 50 cm - Dimensions of packed product (W×H×D): 101,5 × 43,5 × 56 cm - Net weight: 11,5 kg - Gross weight: 16,4 kg - Connected load: 141 W 	<ul style="list-style-type: none"> - Noise level (max.): 62 dB(A)re 1 pW - Min. height of the chimney: 545 mm - Max. height of the chimney: 875 mm - Annual energy consumption: 62,2 kWh - Dimensions (W×H×D): 60 × 25 × 50 cm - Dimensions of packed product (W×H×D): 64,5 × 63,7 × 36,5 cm - Net weight: 8,6 kg - Gross weight: 11,2 kg - Connected load: 141 W

**WHC 923 E14X**

Essential Line

Wall mounted cooker hood



- Venting with air extraction or recirculation
- Material of housing/chimney: Stainless steel / Stainless steel
- Colour of housing/chimney: Stainless steel / Stainless steel

**WHC 623 E14X**

Essential Line

Wall mounted cooker hood



- Venting with air extraction or recirculation
- Material of housing/chimney: Stainless steel / Stainless steel
- Colour of housing/chimney: Stainless steel / Stainless steel

Efficiency	<ul style="list-style-type: none"> - Maximum extraction rate by extraction operation: 412 m³/h - Venting tube diameter: 15 cm 	<ul style="list-style-type: none"> - Maximum extraction rate by extraction operation: 408 m³/h - Maximum extraction rate by recirculation operation: 300 m³/h - Venting tube diameter: 15 cm
The capacity of ventilator	<ul style="list-style-type: none"> - Air flow by extraction version, step 1: 258 m³/h - Air flow by extraction version, step 2: 356 m³/h - Air flow by extraction version, step 3: 412 m³/h 	<ul style="list-style-type: none"> - Air flow by extraction version, step 1: 250 m³/h - Air flow by extraction version, step 2: 348 m³/h - Air flow by extraction version, step 3: 408 m³/h
Control	<ul style="list-style-type: none"> - Mechanic control - Control setting: Button control - Number of speed positions: 3 	<ul style="list-style-type: none"> - Mechanic control - Control setting: Button control - Number of speed positions: 3
Features	<ul style="list-style-type: none"> - Lamp type: LED - On/off light switch - Number of lights: 2 - Total power of lights: 6 W 	<ul style="list-style-type: none"> - Lamp type: LED - On/off light switch - Number of lights: 2 - Total power of lights: 6 W
Equipment	<ul style="list-style-type: none"> - Filter material: Washable aluminium with polyurethane foam - Number of motors: 1 - Motor type: Capacitor motor - No return airflow flap: 150 mm 	<ul style="list-style-type: none"> - Filter material: Washable aluminium with polyurethane foam - Number of motors: 1 - Motor type: Capacitor motor - No return airflow flap: 150 mm
Technical data	<ul style="list-style-type: none"> - Noise level (max.): 65 dB(A)re 1 pW - Min. height of the chimney: 545 mm - Max. height of the chimney: 875 mm - Annual energy consumption: 59,9 kWh - Dimensions (W×H×D): 90 × 25 × 50 cm - Dimensions of packed product (W×H×D): 101,5 × 43,5 × 56 cm - Net weight: 11,5 kg - Gross weight: 16,5 kg - Connected load: 126 W 	<ul style="list-style-type: none"> - Noise level (max.): 65 dB(A)re 1 pW - Min. height of the chimney: 545 mm - Max. height of the chimney: 875 mm - Annual energy consumption: 61,5 kWh - Dimensions (W×H×D): 60 × 25 × 50 cm - Dimensions of packed product (W×H×D): 64,5 × 63,7 × 36,5 cm - Net weight: 8,6 kg - Gross weight: 11,36 kg - Connected load: 126 W



BHP 923 E13X Essential Line
Built-in telescopic cooker hood



- Venting with air extraction or recirculation
- Material of housing/chimney: Stainless steel and varnished metal
- Colour of housing/chimney: Stainless steel



BHP 623 E11X Essential Line
Built-in telescopic cooker hood



- Venting with air extraction or recirculation
- Material of housing/chimney: Stainless steel and varnished metal
- Colour of housing/chimney: Stainless steel

Efficiency	<ul style="list-style-type: none"> - Maximum extraction rate by extraction operation: 647 m³/h - Maximum extraction rate by recirculation operation: 499 m³/h - Venting tube diameter: 15 cm 	<ul style="list-style-type: none"> - Maximum extraction rate by extraction operation: 368 m³/h - Maximum extraction rate by recirculation operation: 180 m³/h - Venting tube diameter: 15 cm
The capacity of ventilator	<ul style="list-style-type: none"> - Air flow by extraction version, step 1: 250 m³/h - Air flow by extraction version, step 2: 433 m³/h - Air flow by extraction version, step 3: 647 m³/h 	<ul style="list-style-type: none"> - Air flow by extraction version, step 1: 267 m³/h - Air flow by extraction version, step 2: 338 m³/h - Air flow by extraction version, step 3: 368 m³/h
Control	<ul style="list-style-type: none"> - Mechanic control - Control setting: Button control - Number of speed positions: 3 	<ul style="list-style-type: none"> - Mechanic control - Control setting: Button control - Number of speed positions: 3
Features	<ul style="list-style-type: none"> - TouchFree Inox - Lamp type: LED - On/off light switch - Number of lights: 2 - Total power of lights: 6 W 	<ul style="list-style-type: none"> - TouchFree Inox - Lamp type: LED - On/off light switch - Number of lights: 2 - Total power of lights: 6 W
Equipment	<ul style="list-style-type: none"> - Filter material: Washable aluminium with polyurethane foam - Number of motors: 1 - Motor type: Capacitor motor - No return airflow flap: 150 mm 	<ul style="list-style-type: none"> - Filter material: Washable aluminium with polyurethane foam - Number of motors: 1 - Motor type: Capacitor motor - No return airflow flap: 150 mm
Technical data	<ul style="list-style-type: none"> - Noise level (max.): 68 dB(A)re 1 pW - Annual energy consumption: 66,4 kWh - Dimensions (W×H×D): 90 × 31 × 30,5 cm - Dimensions of packed product (W×H×D): 100 × 37 × 37 cm - Net weight: 14,2 kg - Gross weight: 16,2 kg - Connected load: 246 W 	<ul style="list-style-type: none"> - Noise level (max.): 71 dB(A)re 1 pW - Annual energy consumption: 55 kWh - Dimensions (W×H×D): 60 × 17 × 30,5 cm - Dimensions of packed product (W×H×D): 66,5 × 36,6 × 23,5 cm - Net weight: 7,2 kg - Gross weight: 8,6 kg - Connected load: 126 W



BHI 611 ES Essential Line

Integrated cooker hood



- Venting with air extraction or recirculation
- Material of housing/chimney: Varnished steel
- Colour of housing/chimney: Grey

Efficiency	<ul style="list-style-type: none"> - Maximum extraction rate by extraction operation: 368 m³/h - Maximum extraction rate by recirculation operation: 176 m³/h - Venting tube diameter: 12 cm
The capacity of ventilator	<ul style="list-style-type: none"> - Air flow by extraction version, step 1: 155 m³/h - Air flow by extraction version, step 3: 368 m³/h
Control	<ul style="list-style-type: none"> - Mechanic control - Control setting: Switch - Number of speed positions: 3
Features	<ul style="list-style-type: none"> - Lamp type: LED - On/off light switch - Number of lights: 2 - Power of lights: 6 W
Equipment	<ul style="list-style-type: none"> - Filter material: Washable aluminium with polyurethane foam - Number of motors: 1
Technical data	<ul style="list-style-type: none"> - Noise level (max.): 67 dB(A)re 1 pW - Annual energy consumption: 70,7 kWh - Dimensions (W×H×D): 53,4 × 17,7 × 25,7 cm - Net weight: 5,3 kg - Gross weight: 6 kg - Connected load: 256 W



WHU 629 ES/S
Undercabinet cooker hood

Essential Line

WHU 629 EW/S
Undercabinet cooker hood

Essential Line

B Energy Class

59,6
cm

- Venting with air extraction or recirculation
- Material of housing/chimney: Varnished steel
- Colour of housing/chimney: Metallic

B Energy Class

59,6
cm

- Venting with air extraction or recirculation
- Material of housing/chimney: Varnished steel
- Colour of housing/chimney: White

Efficiency	<ul style="list-style-type: none"> - Maximum extraction rate by extraction operation: 200 m³/h - Maximum extraction rate by recirculation operation: 115 m³/h - Venting tube diameter: 12,5 cm 	<ul style="list-style-type: none"> - Maximum extraction rate by extraction operation: 200 m³/h - Maximum extraction rate by recirculation operation: 115 m³/h - Venting tube diameter: 12,5 cm
The capacity of ventilator	<ul style="list-style-type: none"> - Air flow by extraction version, step 1: 108 m³/h - Air flow by extraction version, step 3: 200 m³/h 	<ul style="list-style-type: none"> - Air flow by extraction version, step 1: 108 m³/h - Air flow by extraction version, step 3: 200 m³/h
Control	<ul style="list-style-type: none"> - Mechanic control - Number of speed positions: 3 	<ul style="list-style-type: none"> - Mechanic control - Number of speed positions: 3
Features	<ul style="list-style-type: none"> - Lamp type: LED - On/off light switch - Number of lights: 1 - Total power of lights: 4 W 	<ul style="list-style-type: none"> - Lamp type: LED - On/off light switch - Number of lights: 1 - Total power of lights: 4 W
Equipment	<ul style="list-style-type: none"> - Filter material: Syntetic - Washable grease filter - Number of motors: 1 - No return airflow flap: 125 mm 	<ul style="list-style-type: none"> - Filter material: Syntetic - Washable grease filter - Number of motors: 1 - No return airflow flap: 125 mm
Technical data	<ul style="list-style-type: none"> - Noise level (max.): 64 dB(A)re 1 pW - Annual energy consumption: 29,1 kWh - Dimensions (W×H×D): 59,6 × 12,5 × 46,8 cm - Dimensions of packed product (W×H×D): 64,6 × 17,8 × 52,4 cm - Net weight: 4,8 kg - Gross weight: 5,49 kg - Connected load: 168 W 	<ul style="list-style-type: none"> - Noise level (max.): 64 dB(A)re 1 pW - Annual energy consumption: 29,1 kWh - Dimensions (W×H×D): 59,6 × 12,5 × 46,8 cm - Dimensions of packed product (W×H×D): 64,6 × 17,8 × 52,4 cm - Net weight: 4,8 kg - Gross weight: 5,49 kg - Connected load: 168 W

GUARDIANS OF VITAMINS

Built-in refrigerators and fridge freezers

Although it is not used for cooking, Gorenje refrigerators are the hub of every kitchen. They are tasked with a simple mission – make sure your favourite food is always available. But Gorenje refrigerators can do much more. They feature smart technologies to mimic the conditions similar to those found in nature, which keeps the food fresh, tasty, and full of vital nutrients for longer. On the inside, they are thoughtfully organized to allow the user optimum view and plenty of space for storage of even larger amounts. On the outside, their superior design introduces a welcome visual accent to any home. Last but not least, they are notoriously charming with their silent and economical operation, and convincing durability.







 **CrispZone with VitaLight and SmartHumidity**
Just like garden-fresh

One of the largest fruit and vegetables bins in the market, CrispZone extends the freshness of your produce with low temperature, automatic humidity control and special light. SmartHumidity keeps the humidity in the drawer at optimum level

at all times thanks to a special membrane which automatically lets out excess moisture. VitaLight maintains the natural ripening process to retain vitamins and keep freshly picked or bought fruit and vegetables fresh and crisp for a longer time.



 **IonAir with DynamiCooling**
Keeps only the pleasant aromas

Air enriched with extra negative ions preserves taste and removes unpleasant odours, while the advanced fan system equalizes the temperature throughout the entire refrigerator and



evenly distributes ionized air, ensuring any type of food can be placed on any shelf.



AdaptTech

A fridge freezer that recognizes your habits

This smart system was devised to maintain the optimum temperature in the refrigerator regardless of how frequently you open the door. When the door is opened, the temperature suddenly rises and the food is exposed to a thermal shock which in turn causes it to perish sooner. The refrigerator continuously monitors and analyzes the way you use it. Thus, it can predict when you will open the fridge door and just before you do, it decreases the temperature by 1 or 2 °C to make sure constant temperature is maintained, ensuring the food stays fresh and full of nutrients.



NoFrost DualAdvance

Optimum double air circulation system

Intensive circulation of cool air in the freezer compartment reduces the humidity level and prevents accumulation of frost on the food and ice on the freezer walls. In the refrigerator compartment, it provides optimum food storage conditions. This leads to optimum cooling and freezing control, each adjusted to the respective processes in the two separate parts of the appliance.

- No more freezer defrosting
- Frozen food will no longer stick together.
- Quality frozen food
- Better view of the contents
- More space
- No exchange of odours between the freezer and refrigerator compartment
- Fresh food will not dry out and remain fresh longer.



FreshZone

Fresh as if straight from nature

The drawer with the lowest temperature in the refrigerator is ideal for storing meat, fish, fruit, and vegetables. It will preserve the food's freshness, aroma, colour, and flavour for much longer.



 **LedLight**
Well-arranged and efficient

LED lighting in refrigerators provides excellent and highly efficient illumination. Its useful life is thirty times as long as that of conventional light bulbs, and it saves up to ten times as much power.



 **MultiAdjust shelves**
Endless storage possibilities

These sturdy glass shelves can be very easily adjusted in position, inserted into the fridge or taken out, thereby allowing you complete freedom to adjust the fridge interior according to your specific needs. The tempered glass shelves are highly durable and will securely carry even larger amounts of food.



 **MixBox**
Keep your fridge neat and tidy

This shallow drawer will store all your smaller items, like spreads, butter, fish cans and snacks making sure your fridge is organized and food doesn't stay forgotten past its due date. Its slide in-and-out function ensures easy access to its content.



FastFreeze Rapid freezing

The FastFreeze function freezes the food at $-24\text{ }^{\circ}\text{C}$ to preserve most of the minerals in the food. After approximately 2 days, the function is switched off automatically and the freezer compartment temperature returns to the initial setting. And in case you forget, smart sensors make sure the function is switched on at the right time.



XXL SpaceBox Enough space to store a turkey

This freezer compartment drawer is the largest in the appliance and it is ideal for storing large items like a turkey, several pizzas, or even cakes.



SuperCool Rapid cooling after weekly shopping

The intensive cooling function drops the refrigerator temperature to $3\text{ }^{\circ}\text{C}$, which is lower than usual by nearly a half. Combined with large refrigerator compartment volume, this temperature is ideal for rapid cooling of food after major shopping trips. After six hours, the function is switched off automatically and the refrigerator compartment temperature returns to the initial setting. And in case you forget, smart sensors make sure the function is switched on at the right time.



MultiBox Multi-functional, practical box

The multi-purpose bin with a lid in the refrigerator door can be used for storing cheese, onions, and other food with a pungent smell. It keeps the food fresh and protects it from drying, while the silicone cover can be used as an egg or ice tray.



 **HiddenSpace**
Extra storage out of sight

The HiddenSpace compartment provides extra hidden storage for cans or similar items underneath the CrispZone drawer.



 **Deep door bottle shelf**
Secure storage for bottles

Refrigerator door has plenty of storage for the largest glass or plastic bottles. A special fence holds the items in place to prevent it from moving and damage while the door is opened or closed.



 **Bottle holder**
The right place for bottles and cans

In Gorenje refrigerators, bottles do not take up the space that could be conveniently used to store other items in the refrigerator door racks or on glass shelves; the designated bottle holder ensures optimum use of storage space.



 **FrostLess**
Less ice, more energy saving

Improved insulation effectively reduces the accumulation of frost on the food and ice in the appliance interior. This means less tedious defrosting and a lower electricity bill.



Flat hinge

Easier door opening and closing

The heavy-duty hinge allows storing heavier items in the door bins, as well as opening the door to an angle of 115°. This allows a clearer look of the interior and makes loading the fridge and taking the food from it more convenient as the door won't keep closing. If the door is left ajar, the hinge will fully close it to save power.



Compressor featuring valve technology

Separate temperature adjustment for refrigerator and freezer

Unlike conventional single-compressor models, those featuring a single compressor with a valve allow separate temperature setting for the refrigerator and freezer compartment. Moreover, cooling for the refrigerator compartment can be switched off while the freezer compartment continues to operate.



A++

Top energy efficiency

All Gorenje fridge freezers are highly energy-efficient. Excellent thermal insulation and door sealing, inverter compressor, and electronic or mechanical control efficiently reduce power consumption. Fridge freezers with the A++ energy efficiency rating use 40% less power than those in the A class.



Side-by-side layout

The perfect couple for your kitchen

The side-by-side layout option allows you to maximise the use of available storage space within a limited surface area and fully adapt it to your needs, as you can combine different appliances (fridges, freezers and even wine chillers).



NRKI 2181 A1 Advanced Line
Built-in integrated fridge freezer

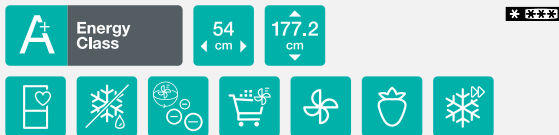

- Colour: White
- Reversible door opening
- Door material: Steel sheet
- Door to door hinge
- Climate class: SN, N, ST, T



NRKI 4181 E1 Essential Line
Built-in integrated fridge freezer

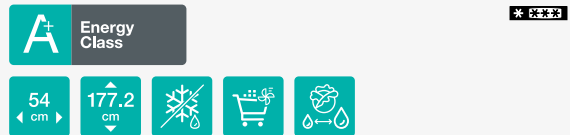

- Colour: White
- Reversible door opening
- Door material: Steel sheet
- Sliding door hinge
- Climate class: N, ST, T

Efficiency	<ul style="list-style-type: none"> - 1 compressor - Total gross/net volume: 269 / 248 l - Capacity of cooling compartment: gross/net: 183 / 180 l - Capacity of freezer compartment: gross/net: 86 / 68 l - Freezing capacity in 24 hours: 8 kg / 24h - Power cut safe time: 16 h 	<ul style="list-style-type: none"> - 1 compressor - Total gross/net volume: 269 / 248 l - Capacity of cooling compartment: gross/net: 183 / 180 l - Capacity of freezer compartment: gross/net: 86 / 68 l - Freezing capacity in 24 hours: 8 kg / 24h - Power cut safe time: 16 h
Control	<ul style="list-style-type: none"> - Electronic control // LED display // Sound alarm for open door - Digital temperature indicator for refrigerator - Sound and visual signal for high temperature in refrigerator: white signal 	<ul style="list-style-type: none"> - Electronic control - LED display - Flashing lighting for open door - Digital temperature indicator for refrigerator
Features	<ul style="list-style-type: none"> - AdaptCool: Adaptive Intelligent System // NoFrost DualAdvance - Fan-assisted cooling in fridge // IonAir with DynamiCooling - SuperCool // FastFreeze // Smart FastFreeze // Smart SuperCool 	<ul style="list-style-type: none"> - NoFrost DualAdvance - SuperCool - Saving programme EcoMode
Equipment of refrigerator	<ul style="list-style-type: none"> - LED strip on the ceiling - 5 glass shelves // MultiAdjust shelves - The wire bottle rack - 2 door trays - 1 single door bottle container with fixed stopper - 1 MultiBox container - CrispZone with VitaLight and SmartHumidity - FreshZone drawer 	<ul style="list-style-type: none"> - Egg/Ice bin: 1 x 7 - LED strip on the ceiling - 5 glass shelves - MultiAdjust shelves - The wire bottle rack - 2 door trays - 1 single door bottle container with fixed stopper - CrispZone with HumidityControl
Equipment of freezer	<ul style="list-style-type: none"> - SpaceBox 38 l // Freezing compartment: 3 drawers - 2 glass shelves 	<ul style="list-style-type: none"> - SpaceBox 38 l // Freezing compartment: 3 drawers - 2 glass shelves
Technical data	<ul style="list-style-type: none"> - Energy consumption kWh/24h: 0,803 kWh - Estimated annual energy consumption: 293 kWh - Noise level: 39 dB(A)re 1 pW - Dimensions (W×H×D): 54 × 177,2 × 54,5 cm - Dimensions of packed product (W×H×D): 58,5 × 183,5 × 65 cm - Niche dimensions (W×H×D): 56-57 × 177,5-178 × 56 cm - Net weight: 66 kg - Gross weight: 68,5 kg - Connected load: 115 W 	<ul style="list-style-type: none"> - Energy consumption kWh/24h: 0,803 kWh - Estimated annual energy consumption: 293 kWh - Noise level: 39 dB(A)re 1 pW - Dimensions (W×H×D): 54 × 177,2 × 54,5 cm - Dimensions of packed product (W×H×D): 58,5 × 183,5 × 65 cm - Niche dimensions (W×H×D): 56-57 × 177,5-178 × 56 cm - Net weight: 64 kg - Gross weight: 66,5 kg - Connected load: 115 W



NRKI 4181 P1 Essential Line
Built-in integrated fridge freezer



- Colour: White
- Door opening: Reversible door opening
- Door material: Steel sheet
- Door hinge: Sliding door hinge
- Climate class: N, ST, T



RKI 4181 E3 Essential Line
Built-in integrated fridge freezer

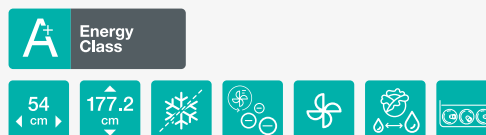

- Colour: White
- Reversible door opening
- Door material: Steel sheet
- Sliding door hinge
- Climate class: N, ST, T

Efficiency	<ul style="list-style-type: none"> - 1 compressor - Total gross/net volume: 256 / 243 l - Capacity of cooling compartment: gross/net: 181 / 180 l - Capacity of freezer compartment: gross/net: 75 / 63 l - Freezing capacity in 24 hours: 3 kg / 24h - Power cut safe time: 12 h 	<ul style="list-style-type: none"> - 1 compressor - Total gross/net volume: 263 / 258 l - Capacity of cooling compartment: gross/net: 190 / 187 l - Capacity of freezer compartment: gross/net: 73 / 71 l - Freezing capacity in 24 hours: 3,5 kg / 24h - Power cut safe time: 18 h
Control	- Mechanic control	- Mechanic control
Features	<ul style="list-style-type: none"> - NoFrost DualAdvance - Fan-assisted cooling in fridge 	<ul style="list-style-type: none"> - FrostLess // Fan-assisted cooling in fridge - IonAir with DynamiCooling - Saving programme EcoMode
Equipment of refrigerator	<ul style="list-style-type: none"> - Egg/Ice bin: 1 x 10 - LED illumination on side - 4 glass shelves - 3 door trays - 1 single door bottle container with fixed stopper - CrispZone with HumidityControl 	<ul style="list-style-type: none"> - Egg/Ice bin: 1 x 7 - LED strip on the ceiling - 5 glass shelves - MultiAdjust shelves - The wire bottle rack // 2 door trays - 1 single door bottle container with fixed stopper - CrispZone with HumidityControl - HiddenSpace
Equipment of freezer	<ul style="list-style-type: none"> - Freezing compartment: 2 drawers - 2 glass shelves 	<ul style="list-style-type: none"> - SpaceBox 38 l // Freezing compartment: 3 drawers - 2 glass shelves
Technical data	<ul style="list-style-type: none"> - Energy consumption kWh/24h: 0,786 kWh - Estimated annual energy consumption: 287 kWh - Noise level: 41 dB(A)re 1 pW - Dimensions (W×H×D): 54 × 177 × 54,5 cm - Dimensions of packed product (W×H×D): 58,5 × 183,5 × 65 cm - Niche dimensions (W×H×D): 56-57 × 177,5-178 × 56 cm - Net weight: 64 kg - Gross weight: 66,5 kg - Connected load: 115 W 	<ul style="list-style-type: none"> - Energy consumption kWh/24h: 0,783 kWh - Estimated annual energy consumption: 286 kWh - Noise level: 38 dB(A)re 1 pW - Dimensions (W×H×D): 54 × 177,2 × 54,5 cm - Dimensions of packed product (W×H×D): 58,5 × 183,5 × 65 cm - Niche dimensions (W×H×D): 56-57 × 177,5-178 × 56 cm - Net weight: 61 kg - Gross weight: 63,5 kg - Connected load: 100 W



RI 2181 A1
Built-in integrated refrigerator

Advanced Line



- Colour: White
- Reversible door opening
- Door material: Steel sheet
- Door to door hinge
- Climate class: SN, N, ST, T



FNI 5182 A1
Built-in upright freezer

Advanced Line

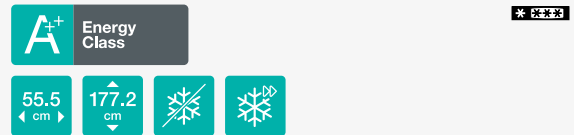

- Colour: White
- Reversible door opening
- Door material: Steel sheet
- Door to door hinge
- Climate class: SN, N, ST, T

Efficiency	<ul style="list-style-type: none"> - 1 compressor - Total gross/net volume: 305 / 301 l - Capacity of cooling compartment: gross/net: 305 / 301 l 	<ul style="list-style-type: none"> - Total gross/net volume: 235 / 212 l - Freezing capacity in 24 hours: 10 kg - Power cut safe time: 12 h
Control	<ul style="list-style-type: none"> - Electronic control // LED display - Sound alarm for open door // Digital temperature indicator for refrigerator - Sound and visual signal for high temperature in refrigerator: white signal 	<ul style="list-style-type: none"> - Electronic control // LED display - Automatic defrost freezer - Digital temperature indicator for freezer - Sound alarm for open door
Features	<ul style="list-style-type: none"> - AdaptCool: Adaptive Intelligent System - Fan-assisted cooling in fridge - IonAir with DynamiCooling // SuperCool 	<ul style="list-style-type: none"> - NoFrost - FastFreeze
Equipment of refrigerator	<ul style="list-style-type: none"> - LED strip on the ceiling - 7 glass shelves // MultiAdjust shelves - The wire bottle rack // 4 door trays - 2 single door bottle containers with fixed stopper - 1 MultiBox container // MixBox - CrispZone with VitaLight and SmartHumidity - FreshZone drawer 	
Equipment of freezer		<ul style="list-style-type: none"> - LED light - 7 glass shelves // SpaceBox 38 l - Freezing compartment: 1 door, 7 drawers
Technical data	<ul style="list-style-type: none"> - Energy consumption kWh/24h: 0,397 kWh - Estimated annual energy consumption: 145 kWh - Noise level: 37 dB(A)re 1 pW - Dimensions (W×H×D): 54 × 177,2 × 54,5 cm - Dimensions of packed product (W×H×D): 58,5 × 183,5 × 65 cm - Niche dimensions (W×H×D): 56-57 × 177,5-178 × 56 cm - Net weight: 62 kg - Gross weight: 64,5 kg - Connected load: 75 W 	<ul style="list-style-type: none"> - Energy consumption kWh/24h: 0,665 kWh - Estimated annual energy consumption: 243 kWh - Noise level: 39 dB(A)re 1 pW - Dimensions (W×H×D): 55,5 × 177,2 × 54,5 cm - Dimensions of packed product (W×H×D): 60 × 183,5 × 65 cm - Niche dimensions (W×H×D): 56-57 × 177,5-178 × 56 cm - Net weight: 69 kg - Gross weight: 71,5 kg - Connected load: 80 W



RI 4181 E1 Essential Line
Built-in integrated fridge freezer



- Colour: White
- Reversible door opening
- Door material: Steel sheet
- Sliding door hinge
- Climate class: SN, N, ST, T



FNI 4181 E1 Essential Line
Built-in upright freezer

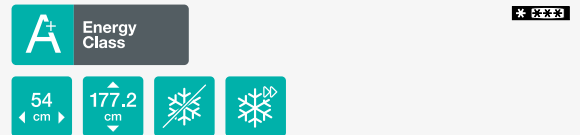

- Colour: White
- Reversible door opening
- Door material: Steel sheet
- Sliding door hinge
- Climate class: SN, N, ST, T

Efficiency	<ul style="list-style-type: none"> - 1 compressor - Total gross/net volume: 305 / 301 l - Capacity of cooling compartment: gross/net: 305 / 301 l 	<ul style="list-style-type: none"> - 1 compressor - Total gross/net volume: 235 / 212 l - Freezing capacity in 24 hours: 10 kg - Power cut safe time: 12 h
Control	<ul style="list-style-type: none"> - Mechanic control 	<ul style="list-style-type: none"> - Electronic control - LED display - Automatic defrost freezer - Digital temperature indicator for freezer
Features	<ul style="list-style-type: none"> - Fan-assisted cooling in fridge - IonAir with DynamiCooling - Saving programme EcoMode 	<ul style="list-style-type: none"> - NoFrost - FastFreeze
Equipment of refrigerator	<ul style="list-style-type: none"> - Egg/Ice bin: 1 x 7 - LED strip on the ceiling - 7 glass shelves // MultiAdjust shelves - The wire bottle rack // 4 door trays - 2 single door bottle containers with fixed stopper - CrispZone with HumidityControl - CrispZone: vegetable drawer 	
Equipment of freezer		<ul style="list-style-type: none"> - LED light - 7 glass shelves // SpaceBox 38 l - Freezing compartment: 1 door, 7 drawers
Technical data	<ul style="list-style-type: none"> - Energy consumption kWh/24h: 0,397 kWh - Estimated annual energy consumption: 145 kWh - Noise level: 37 dB(A)re 1 pW - Dimensions (W×H×D): 54 × 177,2 × 54,5 cm - Dimensions of packed product (W×H×D): 58,5 × 183,5 × 65 cm - Niche dimensions (W×H×D): 56-57 × 177,5-178 × 56 cm - Net weight: 58,5 kg - Gross weight: 61 kg - Connected load: 75 W 	<ul style="list-style-type: none"> - Energy consumption kWh/24h: 0,849 kWh - Estimated annual energy consumption: 310 kWh - Noise level: 41 dB(A)re 1 pW - Dimensions (W×H×D): 54 × 177,2 × 54,5 cm - Dimensions of packed product (W×H×D): 58,5 × 183,5 × 65 cm - Niche dimensions (W×H×D): 56-57 × 177,5-178 × 56 cm - Net weight: 69 kg - Gross weight: 71,5 kg - Connected load: 80 W



RBI 4121 E1
Built-in integrated refrigerator

Essential Line

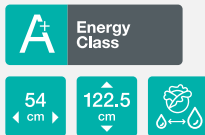

- Colour: White
- Reversible door opening
- Door material: Steel sheet
- Sliding door hinge
- Climate class: SN, N, ST



RBI 4091 E1
Built-in integrated refrigerator

Essential Line



- Colour: White
- Reversible door opening
- Door material: Steel sheet
- Sliding door hinge
- Climate class: SN, N, ST

Efficiency	<ul style="list-style-type: none"> - 1 compressor - Total gross/net volume: 186 / 180 l - Capacity of cooling compartment: gross/net: 171 / 165 l - Capacity of freezer compartment: gross/net: 15 / 15 l - Freezing capacity in 24 hours: 2 kg / 24h - Power cut safe time: 14 h 	<ul style="list-style-type: none"> - 1 compressor - Total gross/net volume: 118 / 114 l - Capacity of cooling compartment: gross/net: 103 / 99 l - Capacity of freezer compartment: gross/net: 15 / 15 l - Freezing capacity in 24 hours: 2 kg / 24h - Power cut safe time: 13 h
Control	- Mechanic control	- Mechanic control
Features	- Saving programme EcoMode	- Saving programme EcoMode
Equipment of refrigerator	<ul style="list-style-type: none"> - LED strip by side - 4 glass shelves - MultiAdjust shelves - 2 door trays - 1 single door bottle container with fixed stopper - CrispZone with HumidityControl 	<ul style="list-style-type: none"> - LED strip by side - 2 glass shelves - MultiAdjust shelves - 1 door tray - 1 single door bottle container with fixed stopper - CrispZone with HumidityControl
Equipment of freezer	<ul style="list-style-type: none"> - Freezing compartment: 1 door - 1 classic ice tray 	<ul style="list-style-type: none"> - Freezing compartment: 1 door - 1 classic ice tray
Technical data	<ul style="list-style-type: none"> - Energy consumption kWh/24h: 0,578 kWh - Estimated annual energy consumption: 211 kWh - Noise level: 39 dB(A)re 1 pW - Dimensions (W×H×D): 54 × 122,5 × 54,5 cm - Dimensions of packed product (W×H×D): 58,5 × 128,5 × 65 cm - Niche dimensions (W×H×D): 56-57 × 122,8-123,3 × 56 cm - Net weight: 41 kg - Gross weight: 43 kg - Connected load: 67 W 	<ul style="list-style-type: none"> - Energy consumption kWh/24h: 0,501 kWh - Estimated annual energy consumption: 183 kWh - Noise level: 39 dB(A)re 1 pW - Dimensions (W×H×D): 54 × 87,5 × 54,5 cm - Dimensions of packed product (W×H×D): 58,5 × 93,5 × 65 cm - Niche dimensions (W×H×D): 56-57 × 87,8-88,3 × 56 cm - Net weight: 35 kg - Gross weight: 37 kg - Connected load: 77 W



RBIU 6091 AW Essential Line

Built-in undercounter refrigerator



- Colour: White
- Reversible door opening
- Door material: Steel sheet
- Door to door hinge
- Climate class: N, ST, T

Efficiency	<ul style="list-style-type: none"> - 1 compressor - Total gross/net volume: 130 / 126 l - Capacity of cooling compartment: gross/net: 109 / 105 l - Capacity of freezer compartment: gross/net: 21 / 21 l - Freezing capacity in 24 hours: 2 kg / 24h - Power cut safe time: 12 h
Control	<ul style="list-style-type: none"> - Mechanic control
Equipment of refrigerator	<ul style="list-style-type: none"> - LED bulb on side - 2 glass shelves - 1 SimpleSlide height adjustable door tray - 1 vegetable drawer - 1 single door bottle container without stopper - 1 MultiBox container - Big glass pull-out tray - Ventilation with fan through base
Equipment of freezer	<ul style="list-style-type: none"> - Freezing compartment: 1 door
Technical data	<ul style="list-style-type: none"> - Energy consumption kWh/24h: 0,506 kWh - Estimated annual energy consumption: 185 kWh - Noise level: 38 dB(A)re 1 pW - Dimensions (W×H×D): 59,6 × 82 × 54,5 cm - Dimensions of packed product (W×H×D): 63,5 × 88 × 60 cm - Niche dimensions (W×H×D): 60 × 82-90 × 55 cm - Net weight: 35 kg - Gross weight: 37 kg - Connected load: 80 W

FRESH – NO MATTER WHAT

Freestanding refrigerators and fridge freezers

Gorenje IonGeneration fridge freezers are designed for maximum freshness. Their IonAir with MultiFlow 360° technology continuously refreshes the air to simulate the natural microclimate and provide perfect storage conditions. With smart, user-friendly functions they seamlessly adapt to your lifestyle. No matter how often you open the fridge door, AdaptTech maintains the optimal temperature and keeps your food in perfect shape, while the NoFrost Plus cooling system prevents the accumulation of frost and eliminates defrosting.







IonAir with the MultiFlow 360° function

Ideal microclimate on every shelf

Advanced technology in the refrigerators emulates the natural process of ionization to keep the food fresh longer. Negatively charged ions generated by the appliance continuously refresh the air to mimic a natural microclimate, thus creating the ideal

environment for fresh food. The MultiFlow 360° ventilation system evenly distributes the ionized air through 14 ventilation slots to maintain constant temperature on every shelf.





AdaptTech

A refrigerator that recognizes your habits

This smart system was devised to maintain the optimum temperature in the refrigerator regardless of how frequently you open the door. When the door is opened, the temperature suddenly rises and the food is exposed to a thermal shock which in turn causes it to perish sooner. The refrigerator

continuously monitors and analyzes the way you use it. Thus, it can predict when you will open the fridge door and just before you do, it decreases the temperature by 1 or 2 °C to make sure constant temperature is maintained and that the food stays fresh and full of nutrients.

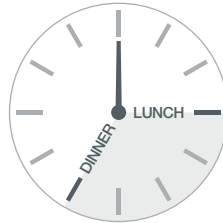

Without ADAPTECH

With ADAPTECH



NoFrost Plus

No more tedious defrosting

One of the best cooling systems in the market, installed in the freezer compartment, prevents the accumulation of ice and frost to keep the power consumption low, while in the refrigerator compartment, it maintains an ideal microclimate for fresh food. Circulation of ionized air prevents the food from drying out and retains its vitamins and minerals.



SensoTech

Advanced control via LED display

Advanced control via LED display allows accurate settings of temperature in the refrigerator and the freezer compartment from the Superior line. Features like XtremeFreeze, FastFreeze, SuperCool, and EcoMode can be switched on by a gentle touch of the relevant symbol. A special signal light and an audible signal warn the user of a sudden increase of the temperature in the appliance.



 **CrispZone drawer featuring HumidityControl**
Just like garden-fresh

CrispZone is one of the largest fruit and vegetables bins in the market. Low temperature and the option to adjust the humidity extend the freshness of your produce.



 **FreshZone**
Fresh as if straight from nature

The drawer with the lowest temperature in the refrigerator is ideal for storing meat, fish, fruit, and vegetables. It will preserve the food's freshness, aroma, colour, and flavour for much longer.



 **SuperCool**
Rapid cooling after weekly shopping

The intensive cooling function drops the refrigerator temperature to 3 °C, which is lower than usual by nearly a half. Combined with large refrigerator compartment volume, this temperature is ideal for rapid cooling of food after major shopping trips. After six hours, the function is switched off automatically and the refrigerator compartment temperature returns to the initial setting.



MultiBox

Multi-functional, practical box

The multi-purpose bin with a cover in the refrigerator door can be used for storing cheese, onions, and other food with a pungent smell. It keeps the food fresh and protects it from drying, while the silicone cover can be used as an egg or ice tray.



XXL SpaceBox

Enough space to store a turkey

This freezer compartment drawer is the largest in the appliance and it is ideal for storing large items like a turkey, several pizzas, or even cakes.



FastFreeze

Rapid freezing

The FastFreeze function freezes the food at -24°C to preserve most of the minerals in the food. After approximately 2 days, the function is switched off automatically and the freezer compartment temperature returns to the initial setting.



SlotIn

No limits for door opening

Owing to the functionality of opening the refrigerator door at a right angle, all shelves and bins can be fully pulled out. This solution is ideal for refrigerators placed against a side wall, or adjacent to a countertop or another appliance.



NRF 7181 TNX
Freestanding fridge freezer



- Colour: Stainless steel
- Reversible door opening
- Climate class: N, T



NRK 6191 GHX
Freestanding fridge freezer

Essential Line



- Colour: Grey metallic
- Reversible door opening
- Door material: Genuine Inox with TouchFree coating
- Climate class: ST, N, T

Efficiency	<ul style="list-style-type: none"> - 1 compressor - Total gross/net volume: 478 / 432 l - Capacity of cooling compartment: gross/net: 353 / 335 l - Capacity of freezer compartment: gross/net: 125 / 97 l - Freezing capacity in 24 hours: 5 kg / 24h - Power cut safe time: 16 h 	<ul style="list-style-type: none"> - 1 compressor - Total gross/net volume: 325 / 307 l - Capacity of cooling compartment: gross/net: 230 / 222 l - Capacity of freezer compartment: gross/net: 95 / 85 l - Freezing capacity in 24 hours: 5 kg / 24h - Power cut safe time: 21 h
Control	<ul style="list-style-type: none"> - Electronic control on door - LCD display - Sound alarm for open door 	<ul style="list-style-type: none"> - Electronic control behind the door - LED display - Digital temperature indicator for refrigerator
Features	<ul style="list-style-type: none"> - NoFrost DualAdvance - Fan-assisted cooling in fridge - Twist ice maker // Water dispenser - SuperCool 	<ul style="list-style-type: none"> - IonAir with MultiFlow 360° - Slot-in: possibility to put the appliance into the kitchen niche 60 cm - NoFrost Plus - FastFreeze // Saving programme EcoMode
Equipment of refrigerator	<ul style="list-style-type: none"> - LED interior light on the ceiling - 3 glass shelves - 5 door trays - 2 vegetable drawers - 1 single door bottle container without stopper - Flexible egg tray 	<ul style="list-style-type: none"> - Egg/Ice bin: 1 x 7 - LED strip on the ceiling - 4 glass shelves // The wire bottle rack - 2 SimpleSlide height adjustable door trays - 1 single door bottle container with fixed stopper - CrispZone with HumidityControl // FreshZone drawer
Equipment of freezer	<ul style="list-style-type: none"> - LED light - 2 door shelves in freezer compartment - 1 glass shelf // 1 classic ice tray 	<ul style="list-style-type: none"> - XXL SpaceBox drawer - Freezing compartment: 3 drawers - 2 glass shelves
Technical data	<ul style="list-style-type: none"> - Water supply: Container - Energy consumption kWh/24h: 1,038 kWh - Noise level: 42 dB(A)re 1 pW - Dimensions (W×H×D): 70 × 183 × 72 cm - Dimensions of packed product (W×H×D): 76,8 × 190,7 × 80,1 cm - Net weight: 70 kg - Gross weight: 77,5 kg - Connected load: 186 W 	<ul style="list-style-type: none"> - Energy consumption kWh/24h: 0,819 kWh - Noise level: 42 dB(A)re 1 pW - Dimensions (W×H×D): 60 × 185 × 64 cm - Dimensions of packed product (W×H×D): 64 × 191 × 75 cm - Net weight: 67,5 kg - Gross weight: 70,5 kg - Connected load: 120 W - Nominal current of fuse: 10 amp



NRK 6191 GHW Essential Line

Freestanding fridge freezer



Energy
Class



- Colour: White
- Reversible door opening
- Door material: Steel sheet
- Climate class: ST, N, T

Efficiency	<ul style="list-style-type: none"> - 1 compressor - Total gross/net volume: 325 / 307 l - Capacity of cooling compartment: gross/net: 230 / 222 l - Capacity of freezer compartment: gross/net: 95 / 85 l - Freezing capacity in 24 hours: 5 kg / 24h - Power cut safe time: 21 h
Control	<ul style="list-style-type: none"> - Electronic control behind the door - LED display - Digital temperature indicator for refrigerator
Features	<ul style="list-style-type: none"> - IonAir with MultiFlow 360° - Slot-in: possibility to put the appliance into the kitchen niche 60 cm - NoFrost Plus - FastFreeze // Saving programme EcoMode
Equipment of refrigerator	<ul style="list-style-type: none"> - Egg/Ice bin: 1 x 7 - LED strip on the ceiling - 4 glass shelves // The wire bottle rack - 2 SimpleSlide height adjustable door trays - 1 single door bottle container with fixed stopper - CrispZone with HumidityControl // FreshZone drawer
Equipment of freezer	<ul style="list-style-type: none"> - XXL SpaceBox drawer - Freezing compartment: 3 drawers - 2 glass shelves
Technical data	<ul style="list-style-type: none"> - Energy consumption kWh/24h: 0,819 kWh - Noise level: 42 dB(A)re 1 pW - Dimensions (W×H×D): 60 × 185 × 64 cm - Dimensions of packed product (W×H×D): 64 × 191 × 75 cm - Net weight: 67,5 kg - Gross weight: 70,5 kg - Connected load: 120 W - Nominal current of fuse: 10 amp



R 6192 LB
Freestanding refrigerator

Colour Edition



- Colour: Black
- Reversible door opening
- Door material: Steel sheet
- Hinged handle
- Climate class: SN, ST, N, T



R 6191 FX
Freestanding refrigerator

Essential Line



- Colour: Grey metallic
- Reversible door opening
- Door material: Genuine Inox with TouchFree coating
- Climate class: SN, ST, N, T

Efficiency	<ul style="list-style-type: none"> - 1 compressor - Total gross/net volume: 370 / 368 l - Capacity of cooling compartment: gross/net: 370 / 368 l 	<ul style="list-style-type: none"> - 1 compressor - Total gross/net volume: 370 / 368 l - Capacity of cooling compartment: gross/net: 370 / 368 l
Control	<ul style="list-style-type: none"> - Electronic control on door - LED display - Sound alarm for open door - Digital temperature indicator for refrigerator - Sound and visual signal for high temperature in refrigerator: white signal 	<ul style="list-style-type: none"> - Mechanic control
Features	<ul style="list-style-type: none"> - AdaptTech cooling: Memorizing intelligent system - Slot-in: possibility to put the appliance into the kitchen niche 60 cm - IonAir with DynamiCooling - SuperCool 	<ul style="list-style-type: none"> - Slot-in: possibility to put the appliance into the kitchen niche 60 cm - IonAir with DynamiCooling
Equipment of refrigerator	<ul style="list-style-type: none"> - LED strip on the ceiling - 7 glass shelves - The wire bottle rack - 3 SimpleSlide height adjustable door trays - Door bottle container: 1 single container with fixed stopper , 1 single container without stopper - 1 MultiBox container - CrispZone with HumidityControl - CrispZone: vegetable drawer - FreshZone drawer 	<ul style="list-style-type: none"> - Egg/Ice bin: 1 x 7 - LED strip on the ceiling - 7 glass shelves - The wire bottle rack - 3 SimpleSlide height adjustable door trays - Door bottle container: 1 single container with fixed stopper , 1 single container without stopper - CrispZone with HumidityControl - CrispZone: vegetable drawer - FreshZone drawer
Technical data	<ul style="list-style-type: none"> - Energy consumption kWh/24h: 0,312 kWh - Noise level: 38 dB(A)re 1 pW - Dimensions (W×H×D): 60 × 185 × 64 cm - Dimensions of packed product (W×H×D): 64 × 191 × 75 cm - Net weight: 63 kg - Gross weight: 66 kg - Connected load: 60 W - Nominal current of fuse: 10 amp 	<ul style="list-style-type: none"> - Energy consumption kWh/24h: 0,397 kWh - Noise level: 38 dB(A)re 1 pW - Dimensions (W×H×D): 60 × 185 × 64 cm - Dimensions of packed product (W×H×D): 64 × 191 × 75 cm - Net weight: 74,5 kg - Gross weight: 77,5 kg - Connected load: 60 W - Nominal current of fuse: 10 amp



R 6191 FW Essential Line

Freestanding refrigerator



- Colour: White
- Reversible door opening
- Door material: Steel sheet
- Climate class: SN, ST, N, T

Efficiency	<ul style="list-style-type: none"> - 1 compressor - Total gross/net volume: 370 / 368 l - Capacity of cooling compartment: gross/net: 370 / 368 l
Control	<ul style="list-style-type: none"> - Mechanic control
Features	<ul style="list-style-type: none"> - Slot-in: possibility to put the appliance into the kitchen niche 60 cm - IonAir with DynamiCooling
Equipment of refrigerator	<ul style="list-style-type: none"> - Egg/Ice bin: 1 x 7 - LED strip on the ceiling - 7 glass shelves - The wire bottle rack - 3 SimpleSlide height adjustable door trays - Door bottle container: 1 single container with fixed stopper , 1 single container without stopper - CrispZone with HumidityControl - CrispZone: vegetable drawer - FreshZone drawer
Technical data	<ul style="list-style-type: none"> - Energy consumption kWh/24h: 0,397 kWh - Noise level: 38 dB(A)re 1 pW - Dimensions (W×H×D): 60 × 185 × 64 cm - Dimensions of packed product (W×H×D): 64 × 191 × 75 cm - Net weight: 74,5 kg - Gross weight: 77,5 kg - Connected load: 60 W - Nominal current of fuse: 10 amp

FROZEN CORRECTLY

Upright and chest freezers

Life on the fast lane and the wish for the best food at any time require much more from an upright or chest freezer than providing space with low temperatures. Gorenje can help out with this. Smart technology in Gorenje upright and chest freezers will make sure the microcrystals formed during the freezing process will not damage the cells in the food. As a result, it will retain its vitamins, minerals, and – most importantly – its flavour. Thus, strawberries picked in the summer will taste just as sweet in the winter, and the ready-made lunch will, although frozen, wait for when you need it in the best shape. The interior is thoughtfully designed to allow neat storage of larger amounts of food.





Recommended storage time in the freezer

TYPE OF FOOD	TIME
fruit, beef	from 10 to 12 months
vegetables, veal, poultry	from 8 to 10 months
venison	from 6 to 8 months
chopped or ground meat	4 months
bread, pastry, cooked meals, lean fish	3 months
entrails	2 months
smoked sausage, fatty fish	1 month



NoFrost

No more tedious defrosting

Intensive circulation of cool air eliminates moisture from the upright freezer. This prevents the accumulation of frost on the food and ice on interior walls and keeps power consumption low. As a result, the usage of the storage capacity is optimal, and defrosting and cleaning of the interior are no longer necessary. Packages or pieces of frozen food will not stick to each other, keeping your food in the freezer neat and tidy.



XXL SpaceBox

Enough space for an XXL turkey

The largest drawer is ideal for storing large items like a turkey, several pizzas, or even cakes.



FastFreeze

Rapid freezing

The FastFreeze function freezes the food at -24 °C to preserve most of the minerals in the food. After approximately 2 days, the function is switched off automatically and the freezer compartment temperature returns to the initial setting.



SensoTech Advanced control

Accurate temperature control via an LED display allows constant temperature control. A dedicated light, combined with an acoustic signal, will warn you of any temperature increases in the appliance.

SimpleUse Comfort guaranteed

Thoughtfully placed light in the chest freezer lid will provide a clear view, and the movable baskets allow easy access to your frozen food. The massive heavy-duty spring-loaded metal hinge will keep the cover partly or fully open so you don't have to hold



FrostLess Less ice, fewer problems

A combination of improved insulation and advanced technology in the chest freezer effectively reduce the accumulation of frost on the food and ice in the appliance interior. This means less frequent defrosting and a lower electricity bill.

it with your hand. Advanced solution that equalizes the pressure to prevent vacuum after the lid is closed allows you to open the chest again immediately after you have closed it.



Control and safety

Mechanical control unit is located at the lower front side of the freezer chest. Temperature settings knob and FastFreeze function on/off key are complemented by two signal lights and a high temperature alarm light.

A+

Improved cooling system provides excellent conditions for attaining the top energy classes. Chest freezers with the A+ energy efficiency rating use 20% less power than those in the A class.

Possibilities of locking

Since the chests are often placed outside the apartment, some models are fitted with a lock. The chest can also be fitted with casters to allow it to be moved around easily.



FN 6192 PB Colour Edition
Upright freezer



FN 6191 CX Essential Line
Upright freezer

A⁺⁺ Energy Class

60 cm 185 cm

A⁺ Energy Class

60 cm 185 cm

- Colour: Black
- Reversible door opening
- Hinged handle
- Climate class: SN, ST, N, T

- Colour: Grey metallic
- Reversible door opening
- Climate class: SN, ST, N, T

Efficiency	<ul style="list-style-type: none"> - 1 compressor - Total gross/net volume: 277 / 243 l - Freezing capacity in 24 hours: 18 kg - Power cut safe time: 15 h - FastFreeze 	<ul style="list-style-type: none"> - 1 compressor - Total gross/net volume: 277 / 243 l - Freezing capacity in 24 hours: 18 kg - Power cut safe time: 15 h - FastFreeze
Control	<ul style="list-style-type: none"> - Electronic control on door - LED display - Slot-in: possibility to put the appliance into the kitchen niche 60 cm - Automatic defrost freezer - NoFrost - Digital temperature indicator for freezer - Sound alarm for open door 	<ul style="list-style-type: none"> - Electronic control behind the door - Slot-in: possibility to put the appliance into the kitchen niche 60 cm - Automatic defrost freezer - NoFrost
Equipment	<ul style="list-style-type: none"> - LED light - 6 glass shelves - Freezing compartment: 1 door, 6 drawers 	<ul style="list-style-type: none"> - LED light - 6 glass shelves - Freezing compartment: 1 door, 6 drawers
Technical data	<ul style="list-style-type: none"> - Energy consumption kWh/24h: 0,649 kWh - Noise level: 42 dB(A)re 1 pW - Dimensions (W×H×D): 60 × 185 × 64 cm - Dimensions of packed product (W×H×D): 64 × 191 × 75 cm - Net weight: 72 kg - Gross weight: 75 kg - Connected load: 100 W - Nominal current of fuse: 10 amp 	<ul style="list-style-type: none"> - Energy consumption kWh/24h: 0,827 kWh - Noise level: 42 dB(A)re 1 pW - Dimensions (W×H×D): 60 × 185 × 64 cm - Dimensions of packed product (W×H×D): 64 × 191 × 75 cm - Net weight: 70 kg - Gross weight: 73 kg - Connected load: 100 W - Nominal current of fuse: 10 amp



FN 6191 CW
Upright freezer

Essential Line

A⁺ Energy Class

60 cm 185 cm

- Colour: White
- Reversible door opening
- Climate class: SN, ST, N, T



F 6151 AW
Upright freezer

Essential Line

A⁺ Energy Class

60 cm 145 cm

- Colour: White
- Reversible door opening
- Climate class: SN, ST, N, T

Efficiency	<ul style="list-style-type: none"> - 1 compressor - Total gross/net volume: 277 / 243 l - Freezing capacity in 24 hours: 18 kg - Power cut safe time: 15 h - FastFreeze 	<ul style="list-style-type: none"> - 1 compressor - Total gross/net volume: 230 / 206 l - Freezing capacity in 24 hours: 18 kg - Power cut safe time: 21 h
Control	<ul style="list-style-type: none"> - Electronic control behind the door - Slot-in: possibility to put the appliance into the kitchen niche 60 cm - Automatic defrost freezer - NoFrost 	<ul style="list-style-type: none"> - Electronic control behind the door - Manual controlled defrost freezer - Visual signal for high temperature in freezer: red signal
Equipment	<ul style="list-style-type: none"> - LED light - 6 glass shelves - Freezing compartment: 1 door, 6 drawers 	<ul style="list-style-type: none"> - Storage compartment: 5 drawers - Freezing compartment: 1 door
Technical data	<ul style="list-style-type: none"> - Energy consumption kWh/24h: 0,827 kWh - Noise level: 42 dB(A)re 1 pW - Dimensions (W×H×D): 60 × 185 × 64 cm - Dimensions of packed product (W×H×D): 64 × 191 × 75 cm - Net weight: 70 kg - Gross weight: 73 kg - Connected load: 100 W - Nominal current of fuse: 10 amp 	<ul style="list-style-type: none"> - Energy consumption kWh/24h: 0,69 kWh - Noise level: 40 dB(A)re 1 pW - Dimensions (W×H×D): 60 × 145 × 64 cm - Dimensions of packed product (W×H×D): 64 × 151 × 73 cm - Net weight: 56 kg - Gross weight: 59 kg - Connected load: 110 W - Nominal current of fuse: 10 amp



FH 400 W
Chest freezer



- Colour: White
- Climate class: T



FH 330 WW
Chest freezer

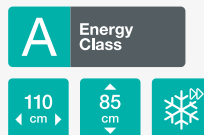

- Colour: White
- Climate class: T

Efficiency	<ul style="list-style-type: none"> - 1 compressor - Total gross/net volume: 400 / 380 l - Freezing capacity in 24 hours: 26 kg - Power cut safe time: 38 h - FastFreeze 	<ul style="list-style-type: none"> - 1 compressor - Total gross/net volume: 325 / 307 l - Freezing capacity in 24 hours: 19 kg - Power cut safe time: 35 h - FastFreeze
Control	<ul style="list-style-type: none"> - Mechanic control - Manual controlled defrost freezer - Visual signal for high temperature in freezer: red signal 	<ul style="list-style-type: none"> - Mechanic control - Manual controlled defrost freezer - Visual signal for high temperature in freezer: red signal
Equipment	<ul style="list-style-type: none"> - Illuminated interior of freezer compartment: Standard in lid - Freezing compartment: 2 baskets - Door lock 	<ul style="list-style-type: none"> - Illuminated interior of freezer compartment: Standard in lid - Freezing compartment: 2 baskets - Door lock - Wheels
Technical data	<ul style="list-style-type: none"> - Energy consumption kWh/24h: 1,126 kWh - Noise level: 43 dB(A)re 1 pW - Dimensions (W×H×D): 130 × 85 × 70 cm - Dimensions of packed product (W×H×D): 134 × 91 × 76 cm - Net weight: 51 kg - Gross weight: 53,7 kg - Connected load: 150 W - Nominal current of fuse: 13 amp 	<ul style="list-style-type: none"> - Energy consumption kWh/24h: 0,992 kWh - Noise level: 42 dB(A)re 1 pW - Dimensions (W×H×D): 110 × 85 × 70 cm - Dimensions of packed product (W×H×D): 114 × 91 × 76 cm - Net weight: 47,5 kg - Gross weight: 49,8 kg - Connected load: 130 W - Nominal current of fuse: 13 amp



FH 330 W
Chest freezer



- Colour: White
- Climate class: T



FH 210 W
Chest freezer



- Colour: White
- Climate class: T



Efficiency	<ul style="list-style-type: none"> - 1 compressor - Total gross/net volume: 325 / 307 l - Freezing capacity in 24 hours: 19 kg - Power cut safe time: 35 h - FastFreeze 	<ul style="list-style-type: none"> - 1 compressor - Total gross/net volume: 210 / 198 l - Freezing capacity in 24 hours: 14 kg - Power cut safe time: 34 h - FastFreeze
Control	<ul style="list-style-type: none"> - Mechanic control - Manual controlled defrost freezer - Visual signal for high temperature in freezer: red signal 	<ul style="list-style-type: none"> - Mechanic control - Manual controlled defrost freezer - Visual signal for high temperature in freezer: red signal
Equipment	<ul style="list-style-type: none"> - Illuminated interior of freezer compartment: Standard in lid - Freezing compartment: 2 baskets - Door lock 	<ul style="list-style-type: none"> - Illuminated interior of freezer compartment: Standard in lid - Freezing compartment: 1 basket - Door lock
Technical data	<ul style="list-style-type: none"> - Energy consumption kWh/24h: 0,992 kWh - Noise level: 42 dB(A)re 1 pW - Dimensions (W×H×D): 110 × 85 × 70 cm - Dimensions of packed product (W×H×D): 114 × 91 × 76 cm - Net weight: 46,5 kg - Gross weight: 48,8 kg - Connected load: 130 W - Nominal current of fuse: 13 amp 	<ul style="list-style-type: none"> - Energy consumption kWh/24h: 0,792 kWh - Noise level: 41 dB(A)re 1 pW - Dimensions (W×H×D): 80 × 85 × 70 cm - Dimensions of packed product (W×H×D): 84 × 91 × 76 cm - Net weight: 40 kg - Gross weight: 41,9 kg - Connected load: 100 W - Nominal current of fuse: 13 amp





SIDE BY SIDE COMBINATIONS



FN 6192 PB

Upright freezer

Colour Edition

R 6192 LB

Freestanding refrigerator

Colour Edition



Energy Class



- Colour: Black
- Reversible door opening
- Hinged handle
- Climate class: SN, ST, N, T

Efficiency

- 1 compressor
- Total gross/net volume: **277 / 243 l**
- Freezing capacity in 24 hours: **18 kg**
- Power cut safe time: **15 h**
- FastFreeze

Control

- Electronic control on door
- Type of display: LED
- Slot-in: possibility to put the appliance into the kitchen niche 60 cm
- Automatic defrost freezer
- NoFrost
- Digital temperature indicator for freezer
- Sound alarm for open door

Equipment

- LED light
- 6 glass shelves
- Freezing compartment: 1 door, 6 drawers

Technical data

- Energy consumption kWh/24h: **0,649 kWh**
- Noise level: **42 dB(A)re 1 pW**
- Dimensions (W×H×D): **60 × 185 × 64 cm**
- Dimensions of packed product (W×H×D): **64 × 191 × 75 cm**
- Net weight: **72 kg**
- Gross weight: **75 kg**
- Connected load: **100 W**
- Nominal current of fuse: **10 amp**

* 2.2.2.3



Energy Class



- Colour: Black
- Reversible door opening
- Door material: Steel sheet
- Hinged handle
- Climate class: SN, ST, N, T

Efficiency

- 1 compressor
- Total gross/net volume: **370 / 368 l**
- Capacity of cooling compartment: gross/net: **370 / 368 l**

Control

- Electronic control on door
- Type of display: LED
- Sound alarm for open door
- Digital temperature indicator for refrigerator
- Sound and visual signal for high temperature in refrigerator: white signal

Features

- AdaptTech cooling: Memorizing intelligent system
- Slot-in: possibility to put the appliance into the kitchen niche 60 cm
- IonAir with DynamiCooling
- SuperCool

Equipment

- Egg/ice bin: 1 x 7 // LED strip on the ceiling // 7 glass shelves // The wire bottle rack // 3 SimpleSlide height adjustable door trays // Door bottle container: 1 single container with fixed stopper , 1 single container without stopper // Number of cheese and butter storage: 1 MultiBox container // CrispZone with HumidityControl // CrispZone: vegetable drawer // FreshZone drawer

Technical data

- Energy consumption kWh/24h: **0,312 kWh**
- Noise level: **38 dB(A)re 1 pW**
- Dimensions (W×H×D): **60 × 185 × 64 cm**
- Dimensions of packed product (W×H×D): **64 × 191 × 75 cm**
- Net weight: **63 kg**
- Gross weight: **66 kg**
- Connected load: **60 W**
- Nominal current of fuse: **10 amp**



FN 6191 CW & R 6191 FW
- Colour: White



FN 6191 CX

Upright freezer

Essential Line

R 6191 FX

Freestanding refrigerator

Essential Line



Energy Class



- Colour: Grey metallic
- Reversible door opening
- Climate class: SN, ST, N, T

Efficiency

- 1 compressor
- Total gross/net volume: **277 / 243 l**
- Freezing capacity in 24 hours: **18 kg**
- Power cut safe time: **15 h**
- FastFreeze

Control

- Electronic control behind the door
- Slot-in: possibility to put the appliance into the kitchen niche 60 cm
- Automatic defrost freezer
- NoFrost

Equipment

- LED light
- 6 glass shelves
- Freezing compartment: 1 door, 6 drawers

Technical data

- Energy consumption kWh/24h: **0,827 kWh**
- Noise level: **42 dB(A)re 1 pW**
- Dimensions (W×H×D): **60 × 185 × 64 cm**
- Dimensions of packed product (W×H×D): **64 × 191 × 75 cm**
- Net weight: **70 kg**
- Gross weight: **73 kg**
- Connected load: **100 W**
- Nominal current of fuse: **10 amp**

* ** ** *

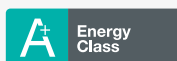

Energy Class



- Colour: Grey metallic
- Reversible door opening
- Door material: Genuine Inox with TouchFree coating
- Climate class: SN, ST, N, T

Efficiency

- 1 compressor
- Total gross/net volume: **370 / 368 l**
- Capacity of cooling compartment: gross/net: **370 / 368 l**

Control

- Mechanic control

Features

- Slot-in: possibility to put the appliance into the kitchen niche 60 cm
- IonAir with DynamiCooling

Equipment

- Egg/Ice bin: 1 x 7 // LED strip on the ceiling // 7 glass shelves // The wire bottle rack // 3 SimpleSlide height adjustable door trays // Door bottle container: 1 single container with fixed stopper , 1 single container without stopper // CrispZone with HumidityControl // CrispZone: vegetable drawer // FreshZone drawer

Technical data

- Energy consumption kWh/24h: **0,397 kWh**
- Noise level: **38 dB(A)re 1 pW**
- Dimensions (W×H×D): **60 × 185 × 64 cm**
- Dimensions of packed product (W×H×D): **64 × 191 × 75 cm**
- Net weight: **74,5 kg**
- Gross weight: **77,5 kg**
- Connected load: **60 W**
- Nominal current of fuse: **10 amp**

A PLEASURE FACTORY

Side by side fridge freezers

Big expectations and high standards require adequately sized refrigerators and freezers. To this end, Gorenje is offering a gallant giant that can easily accommodate a week's stock of food for a large family and prove equally hospitable when hosting a social evening or a party. The refrigerator interior is conveniently and clearly organized, and chilled food is always readily available. One special feature of these refrigerators is the double door in which a mini ice cube maker can be integrated. This will save you from any awkward moments or frustration even in case of surprise visits or large gatherings, and during hot summer days.







The luxury of freshness

Enough space for large families as well

The luxury of freshness, convenient double door, appealing design, and environmentally friendly power consumption. A very spacious Side by Side refrigerator with innovatively designed interior offers enough space even for a week's worth of supplies of a large family. The food can be stored on glass shelves, in large drawers, or on deep shelves on the inner wall of the door.



NoFrost

No more tedious defrosting

Intensive circulation of cool air eliminates moisture from both the freezer and refrigerator compartment. This prevents the accumulation of frost on the food and ice on interior walls and keeps power consumption low. As a result, the usage of the storage capacity is optimal, and defrosting and cleaning of the freezer interior are longer necessary. Packages or pieces of frozen food will not stick to each other, keeping your food in the freezer neat and tidy.



SuperCool

Rapid cooling after weekly shopping

The intensive cooling function drops the refrigerator temperature to 3 °C, which is lower than usual by nearly a half. Combined with large volume, this temperature is ideal for rapid cooling of food after major shopping trips. After six hours, the function is switched off automatically and the refrigerator compartment temperature returns to the initial setting.



FastFreeze

Rapid freezing

The FastFreeze function freezes the food at -24 °C to preserve most of the minerals in the food. After approximately 2 days, the function is switched off automatically and the freezer compartment temperature returns to the initial setting.



NRS 9181 VXB

Side by side freestanding fridge freezer



- Colour: Stainless steel
- Door opening: Refrigerator right / freezer left door opening
- Climate class: SN, T



NRS 9182 MX

Side by side freestanding fridge freezer



- Colour: Stainless steel
- Door opening: Refrigerator right / freezer left door opening
- Door material: Steel sheet
- Climate class: SN, N, ST, T

Efficiency	<ul style="list-style-type: none"> - Inverter compressor - Total gross/net volume: 605 / 532 l - Capacity of cooling compartment: gross/net: 381 / 365 l - Capacity of freezer compartment: gross/net: 224 / 167 l - Freezing capacity in 24 hours: 12 kg / 24h - Power cut safe time: 8 h 	<ul style="list-style-type: none"> - Inverter compressor - Total gross/net volume: 566 / 516 l - Capacity of cooling compartment: gross/net: 350 / 339 l - Capacity of freezer compartment: gross/net: 216 / 177 l - Freezing capacity in 24 hours: 11 kg / 24h - Power cut safe time: 10 h
Control	<ul style="list-style-type: none"> - Electronic control on door - LED display - Sound alarm for open door 	<ul style="list-style-type: none"> - Electronic control on door - LED display - Sound alarm for open door
Features	<ul style="list-style-type: none"> - Total NoFrost - Ice maker: Automatic ice making, Ice cubes, Crushed ice - Water dispenser - SuperCool - FastFreeze 	<ul style="list-style-type: none"> - Total NoFrost - Ice maker: Twist ice maker - SuperCool - FastFreeze
Equipment of refrigerator	<ul style="list-style-type: none"> - LED interior light on the ceiling - HomeBar - 5 glass shelves - 5 door trays - 2 vegetable drawers - Flexible egg tray 	<ul style="list-style-type: none"> - LED interior light on the ceiling - 5 glass shelves - 1 meat container - 4 door trays - 2 vegetable drawers - Flexible egg tray
Equipment of freezer	<ul style="list-style-type: none"> - Illuminated interior of freezer compartment: LED light - Freezing compartment: 2 drawers - 3 shelves in freezer door - 5 glass shelves 	<ul style="list-style-type: none"> - Illuminated interior of freezer compartment: LED light - Freezing compartment: 2 drawers - 4 shelves in freezer door - 5 glass shelves
Technical data	<ul style="list-style-type: none"> - Water supply: Container - Energy consumption kWh/24h: 1,197 kWh - Noise level: 43 dB(A)re 1 pW - Dimensions (W×H×D): 91 × 179,3 × 68,7 cm - Dimensions of packed product (W×H×D): 98,2 × 187,7 × 78 cm - Net weight: 110 kg - Gross weight: 121 kg - Connected load: 252 W 	<ul style="list-style-type: none"> - Energy consumption kWh/24h: 0,94 kWh - Noise level: 43 dB(A)re 1 pW - Dimensions (W×H×D): 91 × 178,6 × 64,3 cm - Dimensions of packed product (W×H×D): 97,7 × 189,6 × 72,7 cm - Net weight: 94 kg - Gross weight: 107 kg - Connected load: 240 W





FULLY QUALIFIED TO DO YOUR JOB.

Smartflex dishwashers from Gorenje

The new SmartFlex dishwashers are inspired by modern lifestyle. Because our everyday life can be quite dynamic we created a generation of dishwasher that takes the load of your shoulders with the help of many advanced features.

The interior is designed in such a way that every dish and piece of cutlery has its place, no matter the shape or size. The baskets are equipped with highlighted movable elements and a customizable basket layout for easy loading, while the cutlery can be perfectly organized on a special tray where it can thoroughly dry out after washing. Furthermore, the SmartFlex dishwashers offer you a variety of helpful functions: a wide range of fast washing options that are among the best in the market and can take care of any load in no time, automatic opening of the door for releasing steam and letting the dishes dry out and the dissolving of bad odors through the natural process of ionization.



16 place settings

As flexible as your time will be

The SmartFlex dishwashers offer enough space for all your needs. Three baskets enable washing up to 16 place settings at a time. The fully flexible interior allows for different loading options, the use is simple and the washing effects are perfect.



15 min SpeedWash

Clean fast so you can slow down

Imagine throwing a dinner party and the dishes from the main course are cleaned in the time it takes to serve dessert. A quick 20 min programme with the SpeedWash function will do your dishes in only 15 minutes. Perfect for handling the volume of dishes created by having multiple guests in the house.



AutoProgramme

Party for two or twelve – the dishes will be spotlessly clean

Sometimes all you need is to give the glassware a light rinse, on other occasions your dishwasher is full of heavy dishes left over from Sunday lunch. The advanced sensor technology will always adjust your dishwashing programme to clean dishes perfectly with optimized water and energy consumption. You do not need special programmes for glass or intensive cleaning – the single AutoProgramme will adapt to all your needs.



ExtraHygiene

Always a clean baby bottle

This option prolongs washing time and increases temperature for 5°C which in combination with intensive programme enables temperature of 75°C, which eliminates most of bacteria. The program that mimics the sterilization process is made for families with babies, for cleaning baby utensils and bottles.



Total AquaStop

Do not worry about water spillage

With the AquaStop safety feature, the dishwasher can be safely left to operate at night as well as in your absence. In case of a leakage or flooding, AquaStop automatically cuts off the water supply while the pump siphons the residual water out of the dishwasher basin. AquaStop remains fully functional over the lifespan of the appliance.



Hot water connection

Higher temperature, lower consumption

Gorenje dishwashers can also be connected to hot water (max. 70 °C) instead of cold. Choosing a hot water connection cuts programme times and reduces the dishwasher's electricity consumption. An environmentally and budget friendly solution for your family.



auto TotalDry
Takes care of itself

After the washing cycle, the dishwasher door automatically opens just slightly to let out the excess steam. This allows fresh air to reach the crockery so the washed items, like plastic dishes, dry completely. Excellent for quick drying with low energy consumption.



IonTech
No smell no worries

Everyone is familiar with the bad smell that comes from a half loaded dishwasher that has been loading for a few days. The advanced IonTech technology built in Gorenje dishwashers operates on the principle of the natural process of ionization, which naturally eliminates odours and keeps your dishwasher fresh, even when it is full of dirty dishes.



9,5L water consumption

Saves time and water

Washing dishes by hand, it takes up to 100l litres of fresh water to clean 12 standard place settings. Washing them in a dishwasher would take 10 times less. The more advanced models are equipped with a special water tank that reduces water consumption to only 6,9l of water per washing cycle.



A+++ low energy consumption

Top energy efficiency

Thanks to the new Inverter PowerDrive motor, optimized programmes and smart solutions like TotalDry Gorenje dishwashers combine perfect cleaning and drying results with very low energy consumption.



Inverter PowerDrive

Remarkable power, high efficiency

The new powerful brushless Inverter PowerDrive motor with speed regulation assures high performance with a notably quieter function, low energy consumption and a longer lifespan.



SmartLook

Dishwasher tailored to your kitchen

The special sliding door mechanism allows for mounting the dishwasher in any type of kitchen cabinet, no matter what the required decorative door length or the kickplate style is. In addition, the built-in anti-siphon enables installing of the dishwasher at an ergonomic height. With no gaps under the door!

**GV 66260**

Superior Line

Fully integrated dishwasher

**GV 63160**

Advanced Line

Fully integrated dishwasher

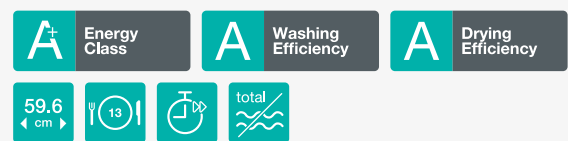

Efficiency	- Max. temperature of inflow water: 70 °C - Asynchronous single phase motor	- Max. temperature of inflow water: 70 °C - Asynchronous single phase motor
Control	- TouchControl	- Control: Button
Programmes	- Washing temperature(s): 70, 65, 55, 45, 35 °C - 5 programmes: Automatic programme; Intensive programme; Eco programme; Rinsing; Quick programme 20 - Reference programme: 3 - Memory programme // Automatic programme - QuickIntensive programme	- Washing temperature(s): 70, 60, 55, 35 °C - 5 programmes: Intensive programme; Eco programme; Rinsing; Daily wash; Quick programme 20 - Reference programme: 3 - Memory programme
Features	- 16 place settings - SpeedWash function - TotalDry – automatic door opening - ExtraHygiene - Function 3 in 1 - Status Light - Visual indicator for wash finish on control panel - Voice signal for the end of washing cycle - Sliding door	- 13 place settings - SpeedWash function - Half load - ExtraDry - Visual indicator for wash finish on control panel
UseLogic technology	- Start delay up to 24 hours	- Start delay up to 24 hours
Equipment	- Number of baskets: 3 - Upper basket system: MultiClack - Foldable bottom plate baskets - Number of water jet levels: 5 // Number of spray arms: 3 - Selfcleaning filter - Upper basket: Wide mesh base; Handle with plastic logotype; Foldable left CupHolder; Foldable right CupHolder; Wide knife stand; One foldable glass support - Lower basket: Wide mesh base; Handle with stainless steel logotype; Foldable/divisible rear pin row - Top tray: With telescopic rails; Handle with stainless steel logotype	- Number of baskets: 2 - Upper basket system: Manual - Number of water jet levels: 4 - Number of spray arms: 2 - Selfcleaning filter - Upper basket: Wide mesh base; Foldable left CupHolder; Fixed pin rows; Fixed glass support - Lower basket: Wide mesh base; Fix pin rows; Cutlery basket
Safety	- Total AquaStop - Service diagnostics - Stainless steel tub	- Total AquaStop - Service diagnostics - Stainless steel tub
Technical data	- Water consumption: 9,5 l - Energy consumption - normal program: 0,86 kWh - Estimated annual water consumption: 2660 l - Noise level (max.): 45 dB(A)re 1 pW - Height setting: 70 mm - Dimensions (W×H×D): 59,6 × 81,7 × 55,6 cm - Dimensions of packed product (W×H×D): 64 × 89 × 66,5 cm - Niche dimensions (W×H×D): 60 × 82 × 57 cm - Net weight: 35,5 kg // Gross weight: 38,1 kg - Connected load: 1900 W - Nominal current of fuse: 10 amp	- Water consumption: 11 l - Energy consumption - normal program: 1,04 kWh - Estimated annual water consumption: 3080 l - Noise level (max.): 47 dB(A)re 1 pW - Height setting: 50 mm - Dimensions (W×H×D): 59,6 × 81,7 × 55,6 cm - Dimensions of packed product (W×H×D): 64 × 89 × 66,5 cm - Niche dimensions (W×H×D): 60 × 82 × 57 cm - Net weight: 32,5 kg // Gross weight: 35,1 kg - Connected load: 1900 W - Nominal current of fuse: 10 amp



GI 66160 S Advanced Line
Semi integrated dishwasher

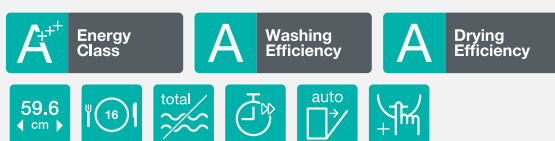

GI 64160 Advanced Line
Semi integrated dishwasher



Efficiency	- Max. temperature of inflow water: 70 °C - Asynchronous single phase motor	- Max. temperature of inflow water: 70 °C - Asynchronous single phase motor
Control	- Control: Button	- Control: Button
Programmes	- Washing temperature(s): 70, 65, 55, 45, 35 °C - 5 programmes: Automatic programme; Intensive programme; Eco programme; Rinsing; Quick programme 20 - Reference programme: 3 - Memory programme // Automatic programme - QuickIntensive programme	- Washing temperature(s): 70, 60, 55, 35 °C - 5 programmes: Intensive programme; Eco programme; Rinsing; Daily wash; Quick programme 20 - Reference programme: 3 - Memory programme
Features	- 16 place settings - SpeedWash function - Half load - TotalDry – automatic door opening - Visual indicator for wash finish on control panel	- 13 place settings - SpeedWash function - Half load - TotalDry – automatic door opening - Visual indicator for wash finish on control panel
UseLogic technology	- Start delay up to 24 hours	- Start delay up to 24 hours
Equipment	- Number of baskets: 3 - Upper basket system: MultiClack - Foldable bottom plate baskets - Number of water jet levels: 5 // Number of spray arms: 3 - Selfcleaning filter - Upper basket: Wide mesh base; Handle with plastic logotype; Foldable left CupHolder; Foldable right CupHolder; Wide knife stand; One foldable glass support - Lower basket: Wide mesh base; Handle with plastic logotype; Foldable/divisible rear pin row - Top tray: With telescopic rails; Handle with plastic logotype	- Number of baskets: 2 - Upper basket system: Manual - Number of water jet levels: 4 - Number of spray arms: 2 - Selfcleaning filter - Upper basket: Wide mesh base; Foldable left CupHolder; Fixed pin rows; Fixed glass support - Lower basket: Wide mesh base; Fix pin rows; Cutlery basket
Safety	- Total AquaStop - Service diagnostics - Stainless steel tub	- Total AquaStop - Service diagnostics - Stainless steel tub
Technical data	- Water consumption: 9,5 l - Energy consumption - normal program: 0,86 kWh - Estimated annual water consumption: 2660 l - Noise level (max.): 45 dB(A)re 1 pW - Height setting: 70 mm - Dimensions (W×H×D): 59,6 × 81,7 × 57,5 cm - Dimensions of packed product (W×H×D): 64 × 89 × 66,5 cm - Niche dimensions (W×H×D): 60 × 82 × 57,6 cm - Net weight: 36,5 kg // Gross weight: 39,1 kg - Connected load: 1900 W - Nominal current of fuse: 10 amp	- Water consumption: 11 l - Energy consumption - normal program: 0,92 kWh - Estimated annual water consumption: 3080 l - Noise level (max.): 47 dB(A)re 1 pW - Height setting: 50 mm - Dimensions (W×H×D): 59,6 × 81,7 × 57,5 cm - Dimensions of packed product (W×H×D): 64 × 89 × 66,5 cm - Niche dimensions (W×H×D): 60 × 82 × 57,6 cm - Net weight: 34 kg // Gross weight: 36,6 kg - Connected load: 1900 W - Nominal current of fuse: 10 amp



GS 66260 X
Freestanding dishwasher

Superior Line



GS 65260 W
Freestanding dishwasher

Superior Line



Efficiency	<ul style="list-style-type: none"> - Max. temperature of inflow water: 70 °C - Inverter PowerDrive motor 	<ul style="list-style-type: none"> - Max. temperature of inflow water: 70 °C - Asynchronous single phase motor
Control	- TouchControl	- TouchControl
Programmes	<ul style="list-style-type: none"> - Washing temperature(s): 70, 65, 55, 45, 35 °C - 5 programmes: Automatic programme; Intensive programme; Eco programme; Rinsing; Quick programme 20 - Reference programme: 3 - Memory programme - Automatic programme - QuickIntensive programme 	<ul style="list-style-type: none"> - Washing temperature(s): 70, 65, 55, 45, 35 °C - 5 programmes: Automatic programme; Intensive programme; Eco programme; Rinsing; Quick programme 20 - Reference programme: 3 - Memory programme - Automatic programme - QuickIntensive programme
Features	<ul style="list-style-type: none"> - 16 place settings - SpeedWash function - TotalDry – automatic door opening - ExtraHygiene - Function 3 in 1 - Visual indicator for wash finish on control panel - Voice signal for the end of washing cycle - IonTech 	<ul style="list-style-type: none"> - 13 place settings - SpeedWash function - TotalDry – automatic door opening - ExtraHygiene - Function 3 in 1 - Visual indicator for wash finish on control panel - Voice signal for the end of washing cycle
UseLogic technology	- Start delay up to 24 hours	- Start delay up to 24 hours
Equipment	<ul style="list-style-type: none"> - Interior light - Number of baskets: 3 - Upper basket system: MultiClack - Foldable bottom plate baskets - Number of water jet levels: 5 // Number of spray arms: 3 - Selfcleaning filter - Upper basket: Wide mesh base; Handle with plastic logotype; Foldable left CupHolder; Foldable right CupHolder; Wide knife stand; One foldable glass support - Lower basket: Wide mesh base; Handle with stainless steel logotype; Foldable/divisible rear pin row - Top tray: With telescopic rails; Handle with stainless steel logotype 	<ul style="list-style-type: none"> - Number of baskets: 2 - Upper basket system: MultiClack - Foldable bottom plate baskets - Number of water jet levels: 4 - Number of spray arms: 2 - Selfcleaning filter - Upper basket: Wide mesh base; Handle with plastic logotype; Foldable left CupHolder; Foldable right CupHolder; Fixed pin rows; Fixed glass support; Standard knife stand - Lower basket: Wide mesh base; Handle with plastic logotype; Foldable/divisible rear pin row; Cutlery basket
Safety	<ul style="list-style-type: none"> - Total AquaStop - Service diagnostics - Stainless steel tub 	<ul style="list-style-type: none"> - Total AquaStop - Service diagnostics - Stainless steel tub
Technical data	<ul style="list-style-type: none"> - Water consumption: 9,5 l - Energy consumption - normal program: 0,86 kWh - Estimated annual water consumption: 2660 l - Noise level (max.): 45 dB(A)re 1 pW - Height setting: 50 mm - Dimensions (W×H×D): 60 × 84,8 × 59,6 cm - Dimensions of packed product (W×H×D): 64 × 92 × 66,5 cm - Net weight: 54,5 kg // Gross weight: 57,1 kg - Connected load: 1900 W - Nominal current of fuse: 10 amp 	<ul style="list-style-type: none"> - Water consumption: 9,5 l - Energy consumption - normal program: 0,92 kWh - Estimated annual water consumption: 2660 l - Noise level (max.): 47 dB(A)re 1 pW - Height setting: 50 mm - Dimensions (W×H×D): 60 × 84,8 × 59,6 cm - Dimensions of packed product (W×H×D): 64 × 92 × 66,5 cm - Net weight: 51 kg // Gross weight: 53,6 kg - Connected load: 1900 W - Nominal current of fuse: 10 amp



GS 63160 S
Freestanding dishwasher

Advanced Line

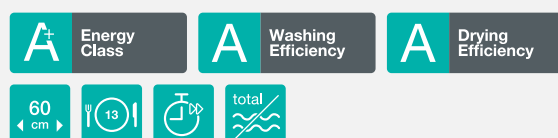

GS 63160 W
Freestanding dishwasher

Advanced Line

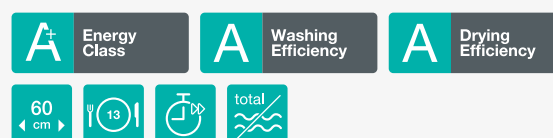

Efficiency	<ul style="list-style-type: none"> - Max. temperature of inflow water: 70 °C - Asynchronous single phase motor 	<ul style="list-style-type: none"> - Max. temperature of inflow water: 70 °C - Asynchronous single phase motor
Control	- Control: Button	- Control: Button
Programmes	<ul style="list-style-type: none"> - Washing temperature(s): 70, 60, 55, 35 °C - 5 programmes: Intensive programme; Eco programme; Rinsing; Daily wash; Quick programme 20 - Reference programme: 1 - Memory programme 	<ul style="list-style-type: none"> - Washing temperature(s): 70, 60, 55, 35 °C - 5 programmes: Intensive programme; Eco programme; Rinsing; Daily wash; Quick programme 20 - Reference programme: 1 - Memory programme
Features	<ul style="list-style-type: none"> - 13 place settings - SpeedWash function - Half load - ExtraDry - Visual indicator for wash finish on control panel 	<ul style="list-style-type: none"> - 13 place settings - SpeedWash function - Half load - ExtraDry - Visual indicator for wash finish on control panel
UseLogic technology	- Start delay up to 24 hours	- Start delay up to 24 hours
Equipment	<ul style="list-style-type: none"> - Number of baskets: 2 - Upper basket system: Manual - Number of water jet levels: 4 - Number of spray arms: 2 - Selfcleaning filter - Upper basket: Wide mesh base; Foldable left CupHolder; Fixed pin rows; Fixed glass support - Lower basket: Wide mesh base; Fix pin rows; Cutlery basket 	<ul style="list-style-type: none"> - Number of baskets: 2 - Upper basket system: Manual - Number of water jet levels: 4 - Number of spray arms: 2 - Selfcleaning filter - Upper basket: Wide mesh base; Foldable left CupHolder; Fixed pin rows; Fixed glass support - Lower basket: Wide mesh base; Fix pin rows; Cutlery basket
Safety	<ul style="list-style-type: none"> - Total AquaStop - Service diagnostics - Stainless steel tub 	<ul style="list-style-type: none"> - Total AquaStop - Service diagnostics - Stainless steel tub
Technical data	<ul style="list-style-type: none"> - Water consumption: 11 l - Energy consumption - normal program: 1,04 kWh - Estimated annual water consumption: 3080 l - Noise level (max.): 47 dB(A)re 1 pW - Height setting: 50 mm - Dimensions (W×H×D): 60 × 84,8 × 59,6 cm - Dimensions of packed product (W×H×D): 64 × 92 × 66,5 cm - Net weight: 51,5 kg // Gross weight: 54,1 kg - Connected load: 1900 W - Nominal current of fuse: 10 amp 	<ul style="list-style-type: none"> - Water consumption: 11 l - Energy consumption - normal program: 1,04 kWh - Estimated annual water consumption: 3080 l - Noise level (max.): 47 dB(A)re 1 pW - Height setting: 50 mm - Dimensions (W×H×D): 60 × 84,8 × 59,6 cm - Dimensions of packed product (W×H×D): 64 × 92 × 66,5 cm - Net weight: 51,5 kg // Gross weight: 54,1 kg - Connected load: 1900 W - Nominal current of fuse: 10 amp





**LIFE IS
COMPLEX.
LET'S MAKE
LAUNDRY
SIMPLE.**

**NEW WaveActive
WASHING MACHINES
AND TUMBLE DRYERS.**

We know you have better things to do than think about washing clothes. That's why we designed the new Gorenje WaveActive washing machines and tumble dryers to provide the best washing results with minimum effort. With their unique IonTech technology they remove up to 30 % more stains and reduce creasing. So you can spend your time on what's really important.



reddot award 2018
winner

ALWAYS FRESH AND TREATED WITH CARE

WaveActive washing machines



New Gorenje WaveActive washing machines use the unique IonTech technology to tackle even the toughest stains with the gentlest care. Using the power of the natural ionisation process ensures best washing results without high temperatures,

additional chemicals, softeners or other irritants, it prevents the deposit of lime scale, which prolongs the machine's life cycle. So you can spend your time on what's really important.



WaveActive drum
Sensitive treatment of any garment

The unique wave-shaped drum pattern in combination with special wave-shaped 3D ribs softens the fibres to provide the most gentle garment treatment for perfectly clean laundry with a minimum wrinkles.



IonTech
Removes 30 % more stains

IonTech uses the power of the natural ionisation process to remove impurities more effectively without high temperatures or additional chemicals. The detergent dissolves better in the water, allowing the cleaning solution to penetrate your laundry evenly. The result is 30 % more stains removed, even at low temperatures. IonTech also prevents the deposit of limescale on the heater which prolongs the washing machine's useful life.



SteamTech
Deep-cleaned and smooth garments, without softeners

Forget softener! Additional steam treatment at the end of the selected programme significantly reduces wrinkles, odours and bacteria. Your garments will be thoroughly clean, less creased and softer.

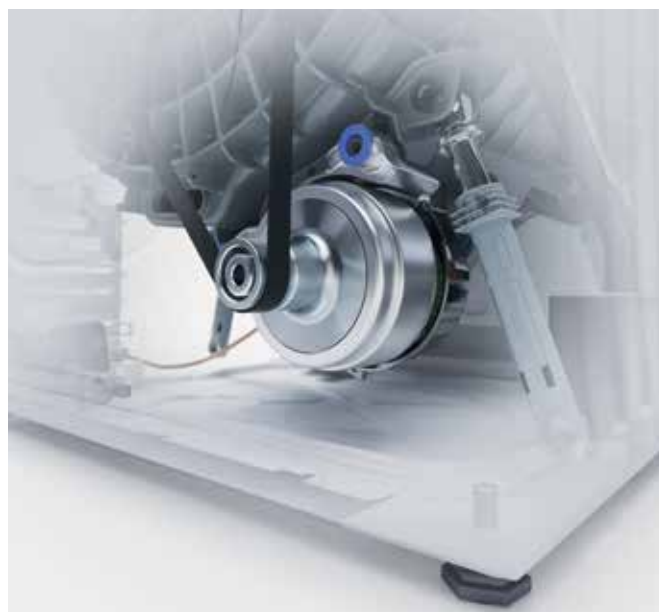

Inverter PowerDrive motor
Powerful, yet silent motor

This quiet, but very efficient motor is designed to ensure a long life of your washing machine, saving energy with each cycle.



StainExpert
The most efficient stain care

Effective removal of stains no longer requires a high temperature or additional treatment of clothing before the wash. The perfect combination of temperature, time, and water will automatically remove up to 36 types of stubborn stains from 3 main groups: fruit (oranges, tomato sauce); organic stains (fat, butter, eggs, grass) and coffee (including tea, chocolate yoghurt, pasta, make-up)



PowerWash 59'
Your favourite items always ready to wear

You will need less than an hour to wash your clothes, thanks to this quick and intensive washing programme suitable for a half load.



DoseAid
Optimal detergent dose for every load

DoseAid will always help you find the optimal dose of detergent, regardless of the amount of load you put in your washing machine, so you can rest assured you're using detergent in the most economical and healthy way.



AutoWash
Always the right programme

Can't decide which programme to choose? Just select AutoWash and your washing machine will select the best washing cycle for your load. You can relax, the clothes will be spotlessly clean, regardless of their material.



SteamRefresh
Always fresh clothes

This unique programme uses a steam generator to produce large quantities of steam, that refresh the clothes and facilitate ironing.



Simple interface
Three steps and you are ready

The easy to use interface with centrally positioned selection knob allows you to start washing in just 3 easy steps; turn on the washing machine, select the programme and press start! Without any submenus for selecting extra functions and settings, but you do have the freedom to the settings on the large touch interface, so you can be sure your garments will be washed just as you like it.



EcoEye
Energy consumption always under control

The easy to read EcoEye indicator gives you real time feedback on how efficient your chosen programme is, helping you save water and energy.



AllergyCare
Extra protection for sensitive skin

The AntiAllergy programme uses a higher temperature and extra rinsing to efficiently eliminate traces of detergent on the fabric. The allergens, that could cause an unpleasant sensation, are removed and delicate skin protected.

FEATURE OVERVIEW

NEW WaveActive washing machines

	PRIMARY	ESSENTIAL	ADVANCED	SUPERIOR
 WaveActive drum	●	●	●	●
 AllergyCare	●	●	●	●
 SteriTub	●	●	●	●
 Sleek door	●	●	●	●
 AutoWash		●	●	●
 Inverter PowerDrive motor		●	●	●
 DoseAid			●	●
 EcoEye			●	●
 Jogger dial			●	●
 Power 59'			●	
 IonTech				●
 IonWash 59'				●
 SuperSilent				●
 Drum Illumination				●
 SteamTech				●



WS 168 LNST
Washing machine

Superior Line

A⁺⁺ Energy Class -20%
A Spinning Efficiency
60 cm
85 cm

10 kg
1600
34 cm
LED
24h

- Colour: White



WA 946 A
Washing machine

Advanced Line

A⁺⁺ Energy Class -20%
B Spinning Efficiency
60 cm
85 cm
9 kg
1400
34 cm
LED
24h

- Colour: Grey metallic

Efficiency	<ul style="list-style-type: none"> - WaveActive drum - SteamTech - Inverter PowerDrive motor - Spin speed: 1600 rpm - Capacity: 1-10 kg - Drum volume: 69 l - Drum illumination 	<ul style="list-style-type: none"> - WaveActive drum - Inverter PowerDrive motor - Spin speed: 1400 rpm - Capacity: 1-9 kg - Drum volume: 64 l
Control	<ul style="list-style-type: none"> - LED display - Presetting time delay of start - Temperature setting - Cold wash: 15 °C - Personal settings for all programmes - Simple interface - EcoEye 	<ul style="list-style-type: none"> - LED display - Presetting time delay of start - Temperature setting - Cold wash: 15 °C - Personal settings for all programmes - Simple interface - EcoEye
Programmes	<ul style="list-style-type: none"> - 14 programmes - Programmes: Cotton, Mix/synthetics, Wool/hand program - Special programmes: AllergyCare, Auto, SportWash, Quick 20', SteamRefresh, IonWash 59' - Modes: NormalCare, EcoCare, TimeCare 	<ul style="list-style-type: none"> - 14 programmes - Programmes: Cotton, Mix/synthetics, Wool/hand program - Special programmes: AllergyCare, Auto, SportWash, PowerWash 59', Quick 20', DownWear - Modes: NormalCare, EcoCare, TimeCare
Features	<ul style="list-style-type: none"> - StableTech side panels // Sleek door // Washing modes - IonTech //DoseAid // StainExpert // Audio signal SoftSound - Self cleaning program SterilTub 	<ul style="list-style-type: none"> - StableTech side panels // Sleek door - Washing modes // DoseAid // Audio signal SoftSound - Self cleaning program SterilTub
Safety and durability	<ul style="list-style-type: none"> - Lockable control pane 	<ul style="list-style-type: none"> - Lockable control pane
Technical data	<ul style="list-style-type: none"> - Estimated annual water consumption: 11314 l - Estimated annual energy consumption: 190 kWh - Noise level (max.): 77 dB(A)re 1 pW - Dimensions (W×H×D): 60 × 85 × 61 cm - Dimensions of packed product (W×H×D): 64 × 91 × 69 cm - Net weight: 83,5 kg - Gross weight: 84,7 kg - Connected load: 2300 W - Nominal current of fuse: 10 amp 	<ul style="list-style-type: none"> - Estimated annual water consumption: 10654 l - Estimated annual energy consumption: 173 kWh - Noise level (max.): 75 dB(A)re 1 pW - Dimensions (W×H×D): 60 × 85 × 61 cm - Dimensions of packed product (W×H×D): 64 × 92 × 69 cm - Net weight: 77 kg - Gross weight: 78,2 kg - Connected load: 2300 W - Nominal current of fuse: 10 amp



WA 946
Washing machine

Advanced Line



- Colour: White



WEI 843 A
Washing machine

Colour Edition

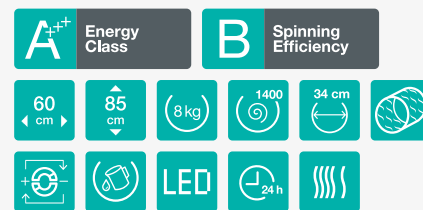

- Colour: Grey metallic

Efficiency	<ul style="list-style-type: none"> - WaveActive drum - Inverter PowerDrive motor - Spin speed: 1400 rpm - Capacity: 1-9 kg - Drum volume: 64 l 	<ul style="list-style-type: none"> - WaveActive drum - Inverter PowerDrive motor - Spin speed: 1400 rpm - Capacity: 1-8 kg - Drum volume: 54 l
Control	<ul style="list-style-type: none"> - LED display - Presetting time delay of start - Temperature setting - Cold wash: 15 °C - Personal settings for all programmes - Simple interface - EcoEye 	<ul style="list-style-type: none"> - LED display - Presetting time delay of start - Personal settings for all programmes - Simple interface
Programmes	<ul style="list-style-type: none"> - 14 programmes - Programmes: Cotton, Mix/synthetics, Wool/hand program - Special programmes: AllergyCare, Auto, SportWash, PowerWash 59', Quick 20', DownWear - Modes: NormalCare, EcoCare, TimeCare 	<ul style="list-style-type: none"> - 16 programmes - Programmes: Cotton, Mix/synthetics, Wool/hand program - Special programmes: AllergyCare, Auto, SportWash, Quick 20', DownWear - Modes: NormalCare, EcoCare, TimeCare
Features	<ul style="list-style-type: none"> - StableTech side panels // Sleek door // Washing modes - DoseAid // Audio signal SoftSound // Self cleaning program SterilTub 	<ul style="list-style-type: none"> - StableTech side panels // Sleek door // Washing modes - Audio signal SoftSound // Self cleaning program SterilTub
Safety and durability	<ul style="list-style-type: none"> - Lockable control pane 	<ul style="list-style-type: none"> - Lockable control pane
Technical data	<ul style="list-style-type: none"> - Estimated annual water consumption: 10654 l - Estimated annual energy consumption: 173 kWh - Noise level (max.): 75 dB(A)re 1 pW - Dimensions (W×H×D): 60 × 85 × 61 cm - Dimensions of packed product (W×H×D): 64 × 92 × 69 cm - Net weight: 77 kg - Gross weight: 78,2 kg - Connected load: 2300 W - Nominal current of fuse: 10 amp 	<ul style="list-style-type: none"> - Estimated annual water consumption: 10309 l - Estimated annual energy consumption: 185 kWh - Noise level (max.): 74 dB(A)re 1 pW - Dimensions (W×H×D): 60 × 85 × 54,5 cm - Dimensions of packed product (W×H×D): 64 × 91 × 62,7 cm - Net weight: 69,5 kg - Gross weight: 70,7 kg - Connected load: 2000 W - Nominal current of fuse: 10 amp



WEI 843 B
Washing machine

Colour Edition

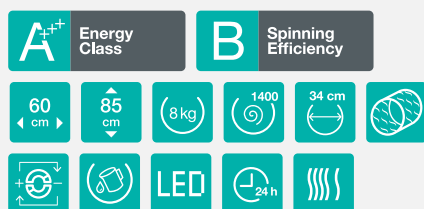

- Colour: Black



WEI 843 R
Washing machine

Colour Edition

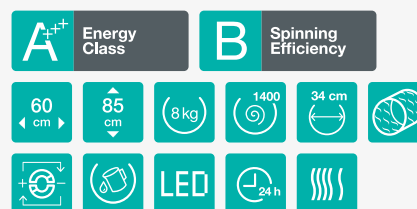

- Colour: Fire Red

Efficiency	<ul style="list-style-type: none"> - WaveActive drum - Inverter PowerDrive motor - Spin speed: 1400 rpm - Capacity: 1-8 kg - Drum volume: 54 l 	<ul style="list-style-type: none"> - WaveActive drum - Inverter PowerDrive motor - Spin speed: 1400 rpm - Capacity: 1-8 kg - Drum volume: 54 l
Control	<ul style="list-style-type: none"> - LED display - Presetting time delay of start - Personal settings for all programmes - Simple interface 	<ul style="list-style-type: none"> - LED display - Presetting time delay of start - Personal settings for all programmes - Simple interface
Programmes	<ul style="list-style-type: none"> - 16 programmes - Programmes: Cotton, Mix/synthetics, Wool/hand program - Special programmes: AllergyCare, Auto, SportWash, Quick 20', DownWear - Modes: NormalCare, EcoCare, TimeCare 	<ul style="list-style-type: none"> - 16 programmes - Programmes: Cotton, Mix/synthetics, Wool/hand program - Special programmes: AllergyCare, Auto, SportWash, Quick 20', DownWear - Modes: NormalCare, EcoCare, TimeCare
Features	<ul style="list-style-type: none"> - StableTech side panels // Sleek door // Washing modes - Audio signal SoftSound // Self cleaning program SterilTub 	<ul style="list-style-type: none"> - StableTech side panels // Sleek door // Washing modes - Audio signal SoftSound // Self cleaning program SterilTub
Safety and durability	<ul style="list-style-type: none"> - Lockable control pane 	<ul style="list-style-type: none"> - Lockable control pane
Technical data	<ul style="list-style-type: none"> - Estimated annual water consumption: 10309 l - Estimated annual energy consumption: 185 kWh - Noise level (max.): 74 dB(A)re 1 pW - Dimensions (W×H×D): 60 × 85 × 54,5 cm - Dimensions of packed product (W×H×D): 64 × 91 × 62,7 cm - Net weight: 69,5 kg - Gross weight: 70,7 kg - Connected load: 2000 W - Nominal current of fuse: 10 amp 	<ul style="list-style-type: none"> - Estimated annual water consumption: 10309 l - Estimated annual energy consumption : 185 kWh - Noise level (max.): 74 dB(A)re 1 pW - Dimensions (W×H×D): 60 × 85 × 54,5 cm - Dimensions of packed product (W×H×D): 64 × 91 × 62,7 cm - Net weight: 69,5 kg - Gross weight: 70,7 kg - Connected load: 2000 W - Nominal current of fuse: 10 amp

**WEI 823**

Essential Line

Washing machine

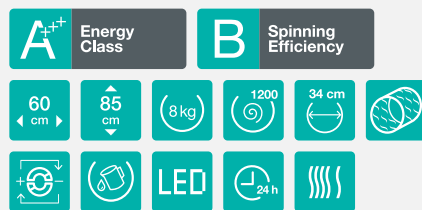

- Colour: White

**WE 723**

Essential Line

Washing machine



- Colour: White

Efficiency	<ul style="list-style-type: none"> - WaveActive drum - Inverter PowerDrive motor - Spin speed: 1200 rpm - Capacity: 1-8 kg - Drum volume: 54 l 	<ul style="list-style-type: none"> - WaveActive drum - Spin speed: 1200 rpm - Capacity: 1-7 kg - Drum volume: 54 l
Control	<ul style="list-style-type: none"> - LED display - Presetting time delay of start - Personal settings for all programmes - Simple interface 	<ul style="list-style-type: none"> - LED display - Presetting time delay of start - Personal settings for all programmes - Simple interface
Programmes	<ul style="list-style-type: none"> - 16 programmes - Programmes: Cotton, Mix/synthetics, Wool/hand program - Special programmes: AllergyCare, Auto, SportWash, Quick 20', DownWear - Modes: NormalCare, EcoCare, TimeCare 	<ul style="list-style-type: none"> - 16 programmes - Programmes: Cotton, Mix/synthetics, Wool/hand program - Special programmes: AllergyCare, Auto, SportWash, Quick 20', DownWear - Modes: NormalCare, EcoCare, TimeCare
Features	<ul style="list-style-type: none"> - StableTech side panels - Sleek door - Washing modes - Audio signal SoftSound - Self cleaning program SterilTub 	<ul style="list-style-type: none"> - StableTech side panels - Sleek door - Washing modes - Audio signal SoftSound - Self cleaning program SterilTub
Safety and durability	<ul style="list-style-type: none"> - Lockable control pane 	<ul style="list-style-type: none"> - Lockable control pane
Technical data	<ul style="list-style-type: none"> - Estimated annual water consumption: 10309 l - Estimated annual energy consumption: 185 kWh - Noise level (max.): 72 dB(A)re 1 pW - Dimensions (W×H×D): 60 × 85 × 54,5 cm - Dimensions of packed product (W×H×D): 64 × 91 × 62,7 cm - Net weight: 69,5 kg - Gross weight: 71,5 kg - Connected load: 2000 W - Nominal current of fuse: 10 amp 	<ul style="list-style-type: none"> - Estimated annual water consumption: 9680 l - Estimated annual energy consumption: 174 kWh - Noise level (max.): 74 dB(A)re 1 pW - Dimensions (W×H×D): 60 × 85 × 54,5 cm - Dimensions of packed product (W×H×D): 64 × 91 × 62,7 cm - Net weight: 69,5 kg - Gross weight: 70,7 kg - Connected load: 2000 W - Nominal current of fuse: 10 amp



WT 72122

Top-loading washing machine

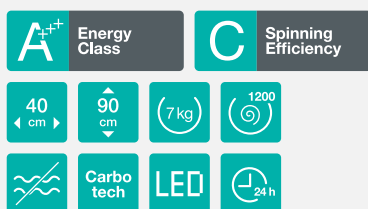

- Colour: White

Efficiency	<ul style="list-style-type: none"> - Spin speed: 1200 rpm - Capacity: 1-7 kg - Drum volume: 42 l
Control	<ul style="list-style-type: none"> - LED display - Presetting time delay of start - Adjustable spin speed - Temperature setting
Programmes	<ul style="list-style-type: none"> - 18 programmes - Programmes: Cotton, Synthetics, Easy care, Wool, Quick, HandWash, Mix - Special programmes: Baby clothes, SportWash, Eco, Cotton 20°C - Easy ironing
Features	<ul style="list-style-type: none"> - SoftOpen: Soft drum opening - 3/4" Cold water connection - Ready-to-open
Safety and durability	<ul style="list-style-type: none"> - Partial AquaStop - Stability Control (SCS)
Technical data	<ul style="list-style-type: none"> - Estimated annual water consumption: 8900 l - Estimated annual energy consumption: 174 kWh - Noise level (max.): 77 dB(A)re 1 pW - Dimensions (W×H×D): 40 × 90 × 60 cm - Dimensions of packed product (W×H×D): 45 × 94 × 70 cm - Net weight: 57 kg - Gross weight: 58 kg - Connected load: 2100 W - Nominal current of fuse: 10 amp



WD 94141
Washing-drying machine



- Colour: White

Efficiency	<ul style="list-style-type: none"> - PowerDrive motor - Spin speed: 1400 rpm - Electric heater - Capacity: 1-9 kg - Dryer load: 1-6 kg - Loading position: Front - Drum volume: 61 l - Door opening angle: 135 ° - 3/4" Cold water connection 	<ul style="list-style-type: none"> - Standard collector motor - Spin speed: 1200 rpm - Electric heater - Capacity: 1-7 kg - Dryer load: 1-5 kg - Loading position: Front - Drum volume: 60 l - Door opening angle: 135 ° - 3/4" Cold water connection
Control	<ul style="list-style-type: none"> - LCD display - Temperature setting - Audio signal SoftSound 	<ul style="list-style-type: none"> - LED display - Temperature setting - Audio signal SoftSound
Programmes	<ul style="list-style-type: none"> - 15 programmes - Programmes: Cotton, Synthetics 	<ul style="list-style-type: none"> - 15 programmes - Programmes: Cotton, Synthetics
Features	<ul style="list-style-type: none"> - Pump STOP // Audio signal SoftSound // Prewash // Skip spin - Temperature setting // Quick wash programme // StartDelay - 4-D soaking // Showering + JET system 	<ul style="list-style-type: none"> - Pump STOP // Audio signal SoftSound - Skip spin // Temperature setting - StartDelay
Safety and durability	<ul style="list-style-type: none"> - Lockable control panel - Electronic door lock - Carbotech tub 	<ul style="list-style-type: none"> - Lockable control panel - Time-attendance door lock - Carbotech tub
Technical data	<ul style="list-style-type: none"> - Estimated annual water consumption: 9800 l - Estimated annual energy consumption: 210 kWh - Noise level washing (max.): 77 dB(A)re 1 pW - Noise level drying: 64 dB(A)re 1 pW - Dimensions (W×H×D): 59,7 × 84,5 × 58,2 cm - Dimensions of packed product (W×H×D): 64,1 × 88,1 × 66 cm - Net weight: 80,5 kg - Gross weight: 83 kg - Connected load: 2200 W - Nominal current of fuse: 10 amp 	<ul style="list-style-type: none"> - Estimated annual water consumption: 10000 l - Estimated annual energy consumption: 246 kWh - Noise level washing (max.): 76 dB(A)re 1 pW - Noise level drying: 66 dB(A)re 1 pW - Dimensions (W×H×D): 59,7 × 84,5 × 58,2 cm - Dimensions of packed product (W×H×D): 64,1 × 88,1 × 66 cm - Net weight: 78 kg - Gross weight: 80 kg - Connected load: 2200 W - Nominal current of fuse: 10 amp



WD 73121
Washing-drying machine



- Colour: White



WDI 73121 HK

Washing-drying machine

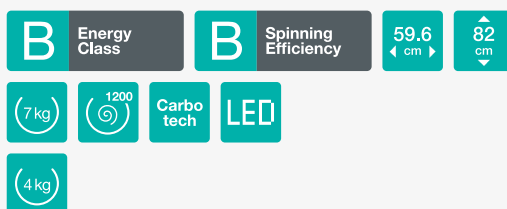

- Colour: White

Efficiency	<ul style="list-style-type: none"> - Spin speed: 1200 rpm - Electric heater - Capacity: 1-7 kg - Dryer load: 1-4 kg - Loading position: Front - Drum volume: 52 l - Door opening angle: 110 ° - 3/4" Cold water connection
Control	<ul style="list-style-type: none"> - LED display - Temperature setting - Audio signal SoftSound
Programmes	<ul style="list-style-type: none"> - 15 programmes - Programmes: Cotton, Synthetics, Easy care, Wool, HandWash - Special programmes: Easy ironing
Features	<ul style="list-style-type: none"> - Pump STOP // Audio signal SoftSound // Prewash // Easy ironing - Skip spin // Temperature setting // Quick wash programme - Extra rinsing // StartDelay 24h // Shower system
Safety and durability	<ul style="list-style-type: none"> - Lockable control panel - Time-attendance door lock - Carbotech tub
Technical data	<ul style="list-style-type: none"> - Estimated annual energy consumption: 10800 l - Estimated annual energy consumption: 170 kWh - Noise level washing (max.): 70 dB(A)re 1 pW - Noise level drying: 58 dB(A)re 1 pW - Dimensions (W×H×D): 59,6 × 82 × 56 cm - Dimensions of packed product (W×H×D): 65 × 88 × 65,5 cm - Niche dimensions (W×H×D): 60 × 82 × 58 cm - Net weight: 82 kg - Gross weight: 85 kg - Connected load: 2200 W - Nominal current of fuse: 10 amp

MORE STEAM FOR LESS IRONING

WaveActive tumble dryers



New Gorenje WaveActive tumble dryers with IonTech technology not only efficiently remove allergens and unpleasant odours, but also significantly reduce creasing. Time-consuming hours of

ironing are minimized, if not eliminated. So you can spend your time on what's really important.



WaveActive drum

Sensitive treatment of any garment

Unique wave-shaped drum pattern softens the fibres the most gentle garment treatment for perfectly dry laundry with minimum wrinkles.

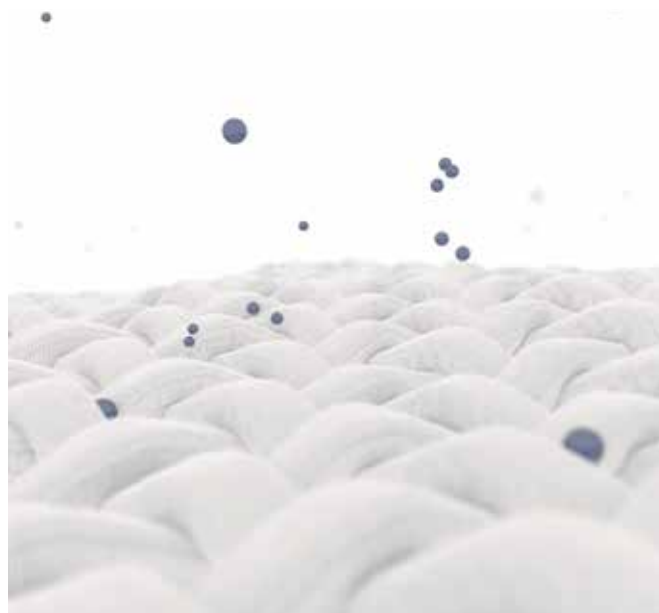

IonTech

Minimize creasing. Maximize freshness

Air full of negatively charged ions dries the laundry in a way that considerably reduces creasing of your clothes. The ionizer creates an environment free of most allergens, smoke residues, pollen and the electrostatic charge accumulated during the drying process. As a result, the clothes are easier to iron and they smell fresh.



SteamTech

For smoother, wrinkle-free clothes

Additional steam treatment at the end of the selected programme will make sure your clothes are much smoother and free of allergens and bacteria. The drum is filled with steam that penetrates every fibre for softer laundry that hardly requires any ironing.



Inverter PowerDrive motor

Powerful, yet silent motor

This quiet, but very efficient motor is designed for a long life of your dryer, saving energy with each cycle.



A **Condensation class A**
Eliminates problems of excess humidity when drying clothes

In each drying cycle WaveActive dryers condense an impressive 90 % of humidity from clothes, ensuring complete dryness of your laundry and eliminating any problems of excess humidity in your home. That means 55 l of water less per year will be released into your living space, compared to tumble dryers with B condensation efficiency class.



SteamRefresh
Clothes free of unpleasant odours and wrinkles

This fifteen-minute steam treatment removes most wrinkles, eliminates any odours and refreshes your blankets, winter jackets, or any other garment, making it the ideal choice when you want to just quickly freshen up your clothes or avoid ironing.



IonRefresh
Quick refreshment for your clothes

Do you need to quickly remove odours from your clothes? With this special refresh program with ions IonRefresh your clothes will be ready to wear and almost as freshly washed in just 30 minutes.



Simple interface
Three steps and you are ready

The easy to use interface with centrally positioned selection knob allows you to start drying in just 3 easy steps; turn on the dryer, select the programme and press start! Without any submenus for selecting extra functions and settings, but you do have the freedom to the settings on the large touch interface, so you can be sure your garments will be dried just as you like it.



TwinAir Efficient drying of even the largest piles of laundry

Even the largest pieces of laundry will be soft, evenly dried and less creased, straight from the dryer thanks to this patented bi-directional air blowing system.



Dryer modes Perfect match for your needs

Our technology makes sure every type of fabric is dried in the best possible way by delivering the optimum combination of temperature, rotation and time. These settings can be further adapted with different drying modes, allowing you to find just the right combination for your current need.



Speed 40⁺ Your favourite items always ready to wear

Your laundry can be dried in only 40 minutes by optimising all stages of drying and using the inverter compressor.



AirRefresh Quick refreshment for your clothes

Special refresh program for refreshment of your clothes after sport activities or after dinner. Fresh air helps to remove odours, food and cigarette smells. In 30 minutes time your clothes are ready to wear and almost as fresh as just being washed.

FEATURE OVERVIEW

NEW WaveActive tumble dryers

	PRIMARY	ESSENTIAL	ADVANCED	SUPERIOR
 Sleek door	●	●	●	●
 Bedding	●	●	●	●
 AirRefresh	●	●		
 Sport Programme	●	●		
 Condensation Class A	●	●	●	●
 HeatPump		●	●	●
 TwinAir		●	●	●
 WaveActive drum			●	●
 IonTech			●	●
 IonRefresh			●	●
 Jogger dial			●	●
 Drum Illumination			●	●
 SteamTech				●
 Inverter PowerDrive				●
 EcoEye				●



DA 92 IL
Heat pump dryer

Advanced Line

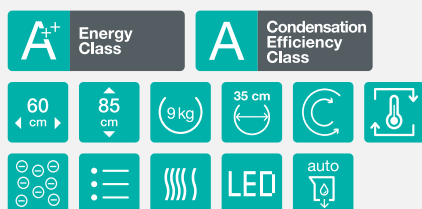

- Colour: White



DE 82 ILA/G
Heat pump dryer

Colour Edition

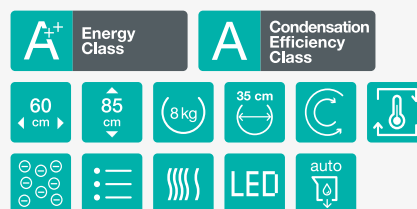

- Colour: Grey metallic

Efficiency	<ul style="list-style-type: none"> - WaveActive drum - StableTech sidings - Dryer load: Large drum volume 1- 9 kg - TwinAir - Drum illumination - Door diameter: 35 cm - Door opening angle: 180 ° - Reversible drum action - Direct discharge of condensate AutoDrain 	<ul style="list-style-type: none"> - WaveActive drum - StableTech sidings - Dryer load: 1-8 kg - TwinAir - Drum illumination - Door diameter: 35 cm - Door opening angle: 180 ° - Reversible drum action - Direct discharge of condensate AutoDrain
Control	<ul style="list-style-type: none"> - Simple interface - Personal settings for all programmes - LED display 	<ul style="list-style-type: none"> - Simple interface - Personal settings for all programmes - LED display
Programmes	<ul style="list-style-type: none"> - 14 programmes - Programmes: Bedding, Wool, Shirts, Mix dry, Mix iron dry, IonRefresh - Drying time selection: Step setting 	<ul style="list-style-type: none"> - 16 programmes - Programmes: Bedding, Wool, Shirts, Sportswear, Mix dry, Mix iron dry, Baby, IonRefresh - Drying time selection: Step setting
Functions	<ul style="list-style-type: none"> - Half load - Dryness level setting - Antcrease - StartDelay - Refresh function 	<ul style="list-style-type: none"> - Half load - Dryness level setting - Antcrease - StartDelay - Refresh function
Features	<ul style="list-style-type: none"> - IonTech technology // Dryer modes // Audio signal SoftSound // Easy filter cleaning // Signal for "full water container" // Remaining time on display // Vacuum feet // Humidity sensor 	<ul style="list-style-type: none"> - IonTech technology // Dryer modes // Audio signal SoftSound // Easy filter cleaning // Signal for "full water container" // Remaining time on display // Vacuum feet // Humidity sensor
Safety and durability	<ul style="list-style-type: none"> - Lockable control panel - Long lasting stainless steel drum 	<ul style="list-style-type: none"> - Lockable control panel - Long lasting stainless steel drum
Technical data	<ul style="list-style-type: none"> - Noise level drying: 65 dB(A)re 1 pW - Estimated annual energy consumption: 259 kWh - Dimensions (W×H×D): 60 × 85 × 62,5 cm - Dimensions of packed product (W×H×D): 64 × 91 × 69 cm - Net weight: 50 kg - Gross weight: 52 kg - Connected load: 800 W - Nominal current of fuse: 10 amp 	<ul style="list-style-type: none"> - Noise level drying: 65 dB(A)re 1 pW - Estimated annual energy consumption: 235 kWh - Dimensions (W×H×D): 60 × 85 × 62,5 cm - Dimensions of packed product (W×H×D): 64 × 91 × 69 cm - Net weight: 50 kg - Gross weight: 52 kg - Connected load: 800 W - Nominal current of fuse: 10 amp



DE 82 ILB/G
Heat pump dryer

Colour Edition

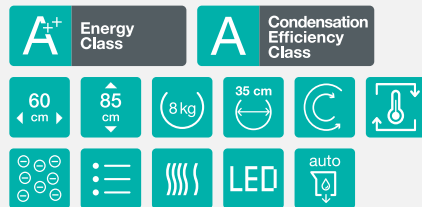

- Colour: Black



DE 7B

Essential Line

Freestanding condenser tumble dryer

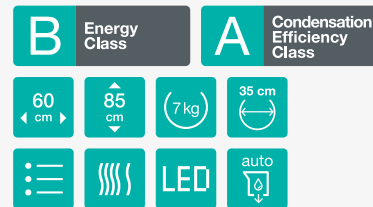

- Colour: White

Efficiency	<ul style="list-style-type: none"> - WaveActive drum - StableTech sidings - Dryer load: 1-8 kg - TwinAir - Drum illumination - Door diameter: 35 cm - Door opening angle: 180 ° - Reversible drum action - Direct discharge of condensate AutoDrain 	<ul style="list-style-type: none"> - StableTech sidings - Dryer load: 1-7 kg - Door diameter: 35 cm - Door opening angle: 180 ° - Reversible drum action - Direct discharge of condensate AutoDrain
Control	<ul style="list-style-type: none"> - Simple interface - Personal settings for all programmes - LED display 	<ul style="list-style-type: none"> - Simple interface - Personal settings for all programmes - Type of display: LED display
Programmes	<ul style="list-style-type: none"> - 16 programmes - Programmes: Bedding, Wool, Shirts, Sportswear, Mix dry, Mix iron dry, Baby, IonRefresh - Drying time selection: Step setting 	<ul style="list-style-type: none"> - 16 programmes - Programmes: Bedding, Wool, Shirts, Sportswear, AirRefresh, Mix dry, Mix iron dry, Baby - Drying time selection: Step setting
Functions	<ul style="list-style-type: none"> - Half load - Dryness level setting - Anticrease - StartDelay - Refresh function 	<ul style="list-style-type: none"> - Dryness level setting - Low temperature option - Anticrease - StartDelay
Features	<ul style="list-style-type: none"> - IonTech technology // Dryer modes // Audio signal SoftSound - Easy filter cleaning // Signal for "full water container" - Remaining time on display // Vacuum feet // Humidity sensor 	<ul style="list-style-type: none"> - Dryer modes // Audio signal SoftSound // Easy filter cleaning - Signal for "full water container" // Remaining time on display - Vacuum feet // Humidity sensor
Safety and durability	<ul style="list-style-type: none"> - Lockable control panel - Long lasting stainless steel drum 	<ul style="list-style-type: none"> - Lockable control panel - Galvanized drum
Technical data	<ul style="list-style-type: none"> - Noise level drying: 65 dB(A)re 1 pW - Estimated annual energy consumption: 235 kWh - Dimensions (W×H×D): 60 × 85 × 62,5 cm - Dimensions of packed product (W×H×D): 64 × 91 × 69 cm - Net weight: 50 kg - Gross weight: 52 kg - Connected load: 800 W - Nominal current of fuse: 10 amp 	<ul style="list-style-type: none"> - Noise level drying: 65 dB(A)re 1 pW - Estimated annual energy consumption: 504 kWh - Dimensions (W×H×D): 60 × 85 × 62,5 cm - Dimensions of packed product (W×H×D): 64 × 91 × 69 cm - Net weight: 40 kg - Gross weight: 42 kg - Connected load: 2500 W - Nominal current of fuse: 16 amp



DP 7C Vented dryer

Primary Line

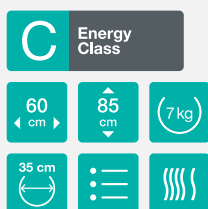

- Colour: White

Efficiency	<ul style="list-style-type: none"> - StableTech sidings - Dryer load: 1-7 kg - Door diameter: 35 cm - Door opening angle: 180 ° - Reversible drum action
Control	<ul style="list-style-type: none"> - Simple interface - Personal settings for all programme
Programmes	<ul style="list-style-type: none"> - 16 programmes - Programmes: Bedding, Wool, Shirts, Sportswear, AirRefresh, Mix dry, Mix iron dry, Baby - Drying time selection: Step setting
Functions	<ul style="list-style-type: none"> - Dryness level setting - Low temperature option - Anticrease - StartDelay
Features	<ul style="list-style-type: none"> - Dryer modes - Easy filter cleaning - Humidity sensor
Safety and durability	<ul style="list-style-type: none"> - Galvanized drum
Technical data	<ul style="list-style-type: none"> - Noise level drying: 64 dB(A)re 1 pW - Estimated annual energy consumption: 475 kWh - Dimensions (W×H×D): 60 × 85 × 62,5 cm - Dimensions of packed product (W×H×D): 64 × 91 × 69 cm - Net weight: 34 kg - Gross weight: 36 kg - Connected load: 2500 W - Nominal current of fuse: 16 amp

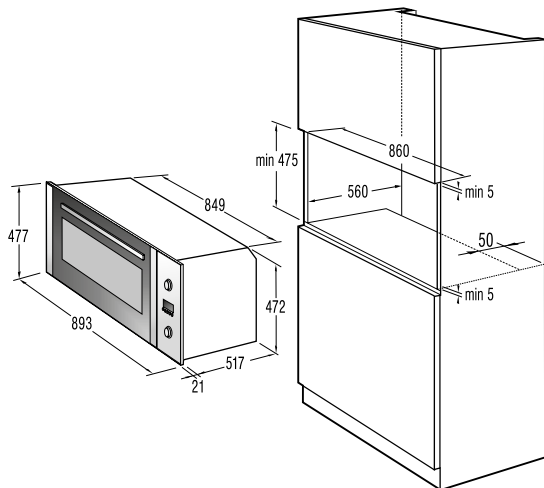

BO 937 E20XG / BO 935 E10X

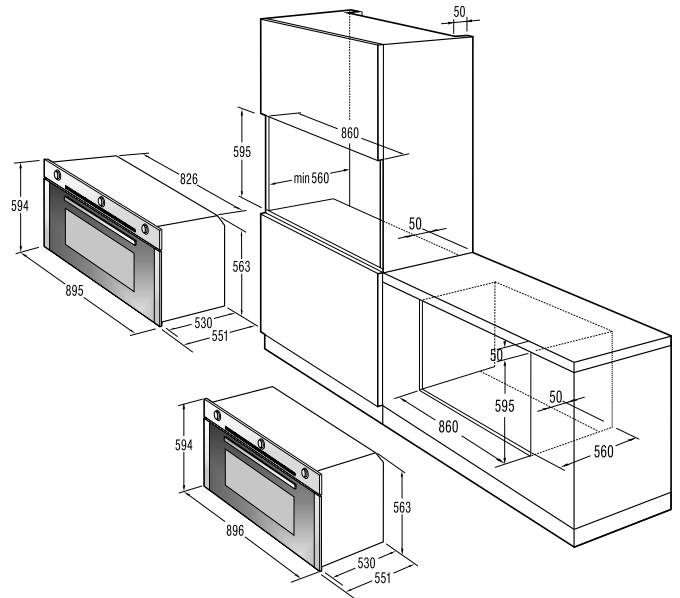

**BOG 932 A20FBG / BOG 932 E10FX
BOG 922 E00FX / BOG 923 E10X**

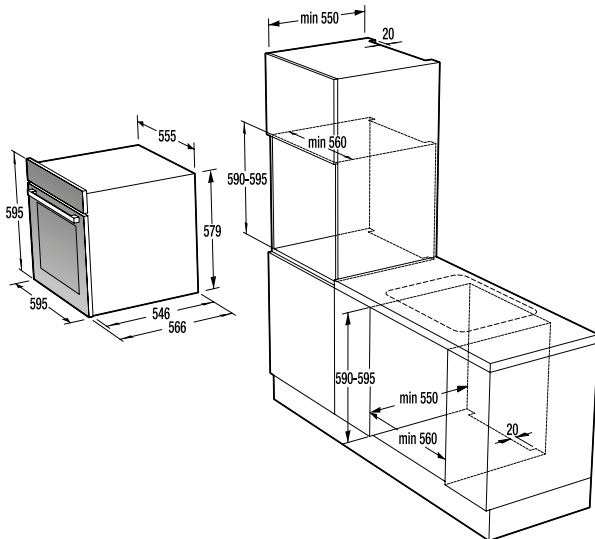

BO... Superior Line / BCS 798 S24X

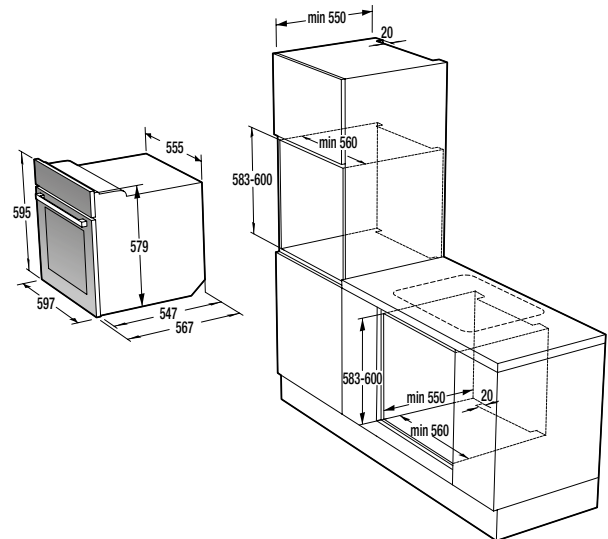

BO... Advanced, Essential Line

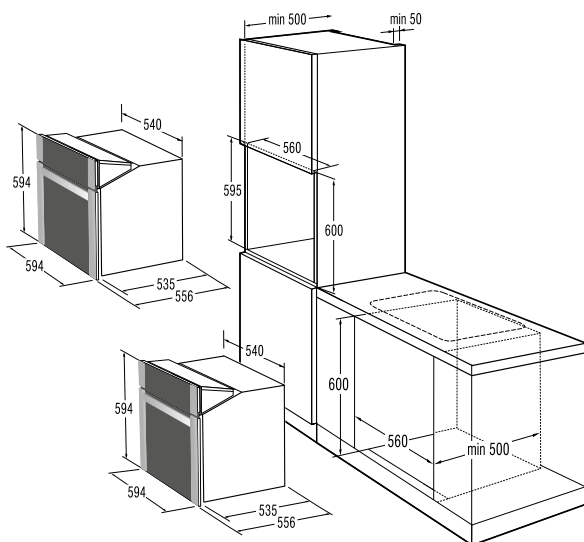

**BOG 632 A20FBG / BOG 632 E10FX / BOG 622 E00FX
BOG 633 E00XGK / BOG 623 E00X**

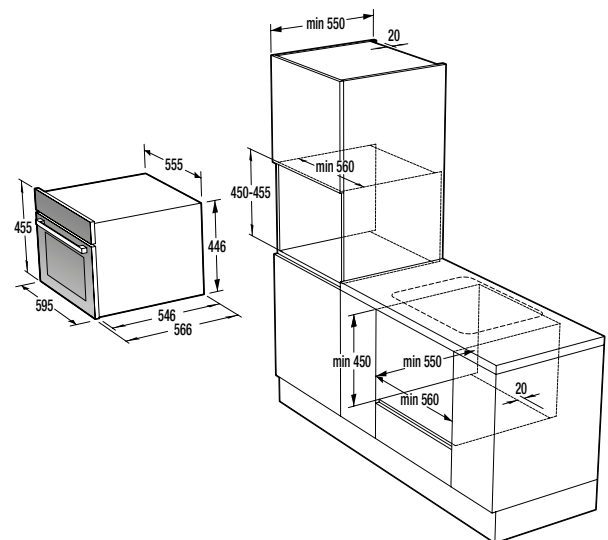

BCS 598 S24X / BCM 598 S18X / BCM 547 S12X

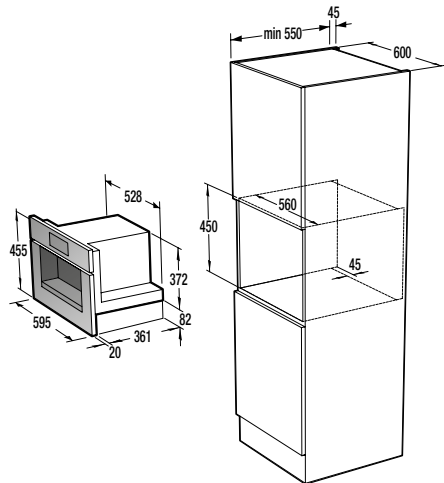

CMA 9200 UX

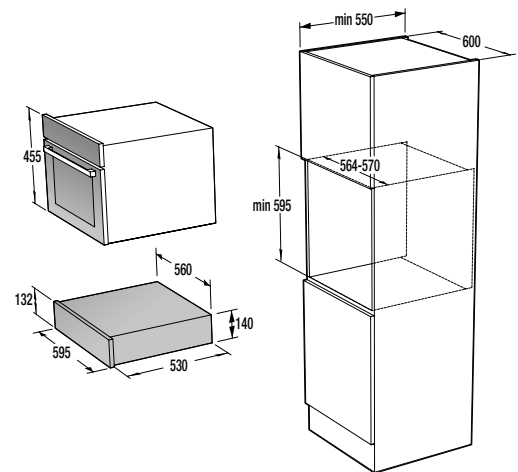

WD 1410 X

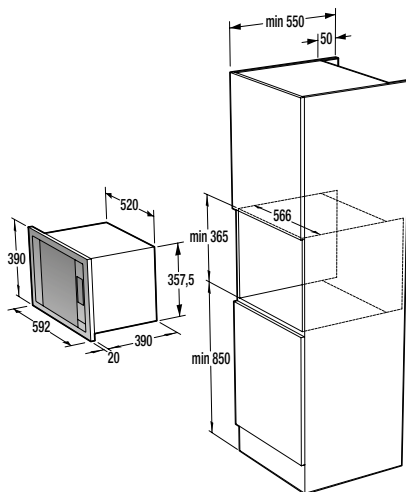

BM 5350 X

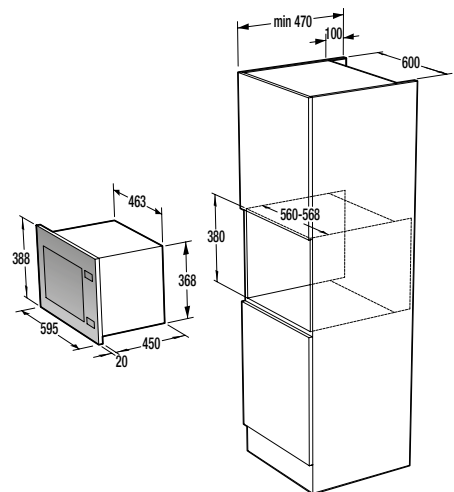

BM 251 S7XG

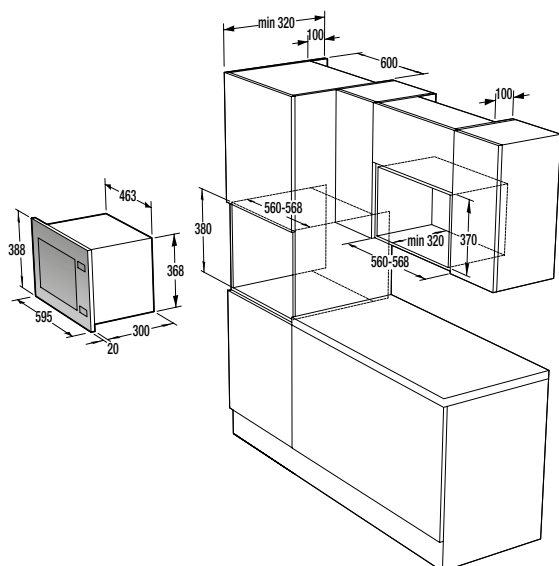

BM 171 A4XG / BM 171 E2XG / BM 171 E2X

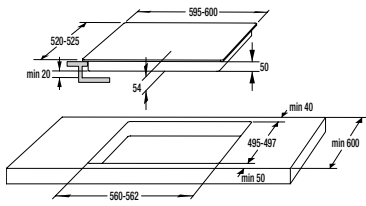

IS 646 BG / IT 642 BSC

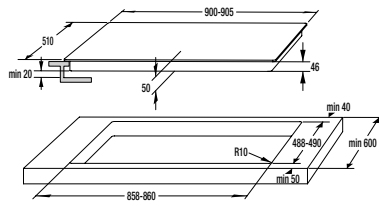

IT 984 USC

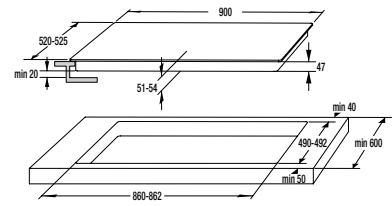

ECS 959 BCSC

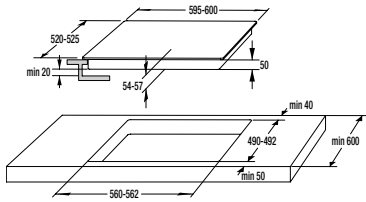

ECS 648 BCSC / ECS 641 BSC-LP

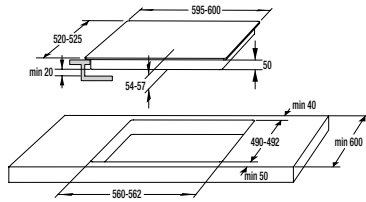

ECT 641 BSC

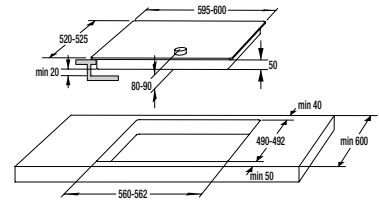

EC 641 BSC

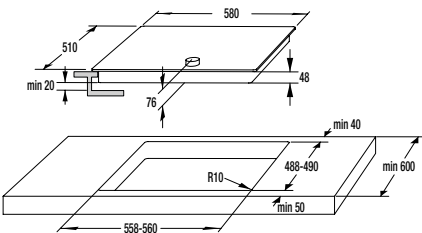

E 6N1 AX

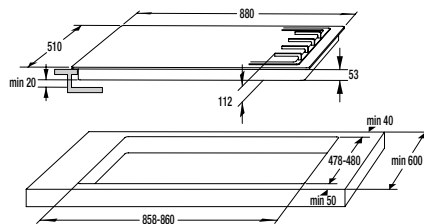

GCW 961 UB

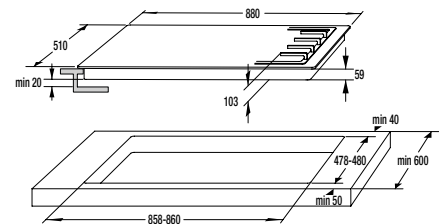

GW 961 UX / GW 951 UX / GW 961 UXB

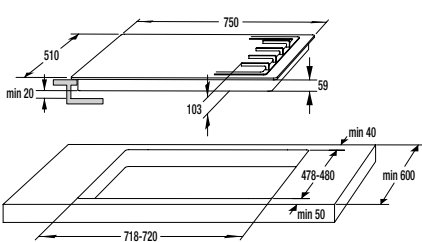

GW 761 UX / GW 760 UX

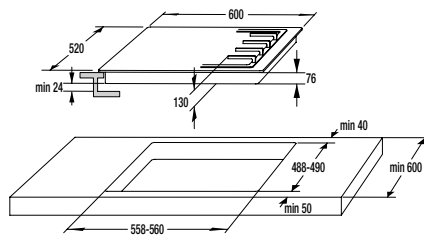

**GW 641 X / W 641 MB
G 641 X / G 640 X / G 6D41 X**

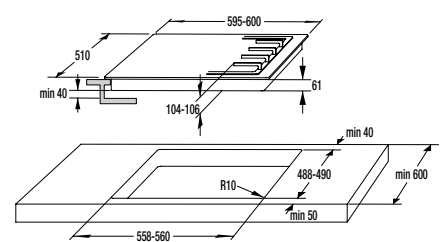

KC 631 USC / KC 621 USC

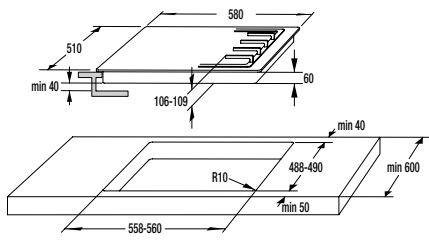

K 6N30 IX

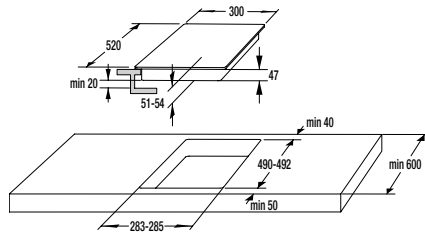

ECT 321 BCSC

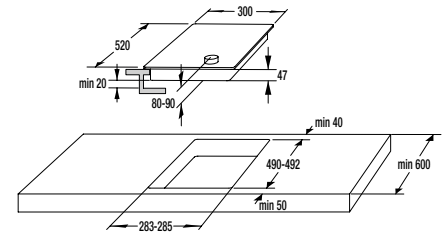

EC 321 BCSC

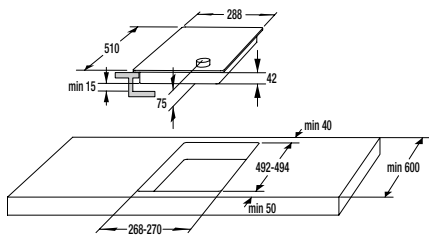

EM 300 E

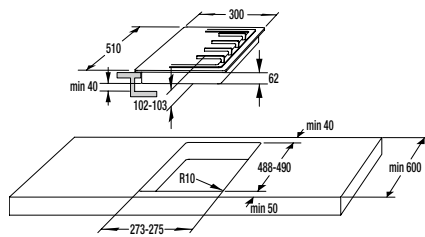

GC 341 UC

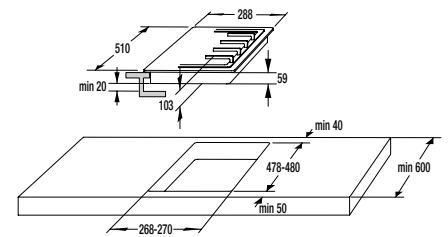

G 340 UX

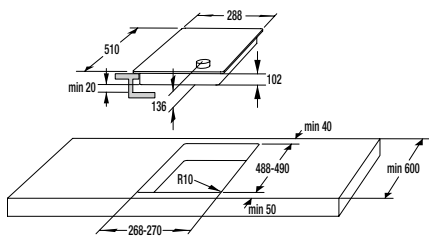

BBQ 2400 X

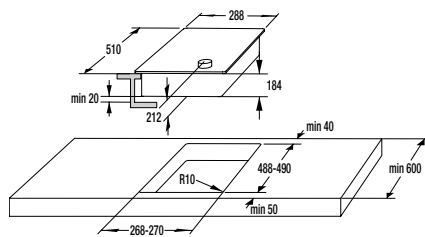

BDF 34 X

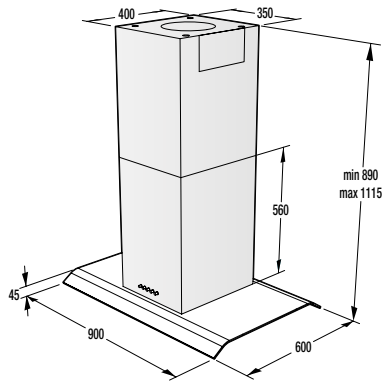

IHGC 933 E16X

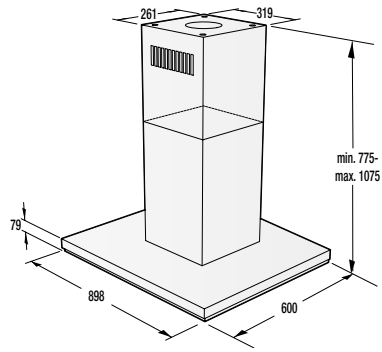

IHT 963 S2X

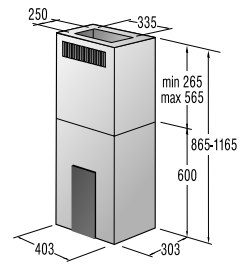

IDQ 4545 X

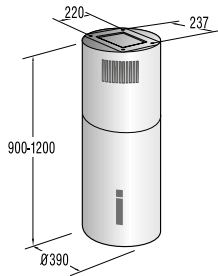

IDR 4545 E

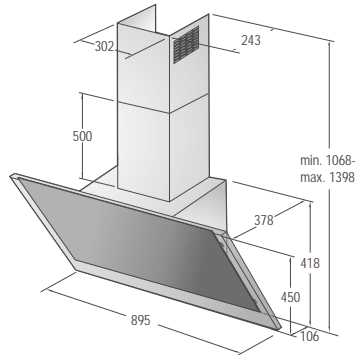

WHI 943 ...

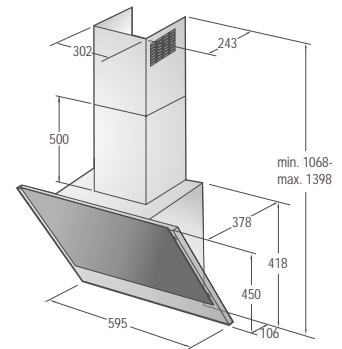

WHI 623 E1XGB

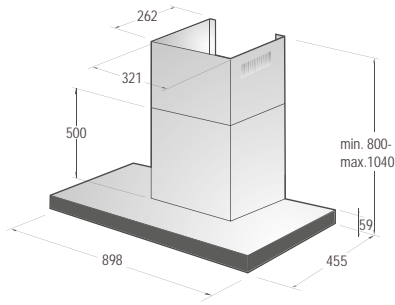

WHT 943 E4XBG

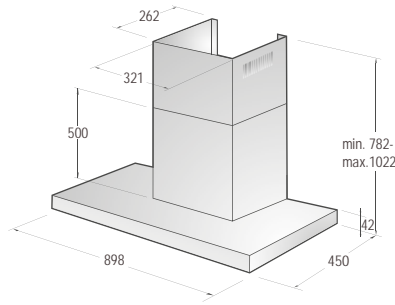

WHT 923 E5X

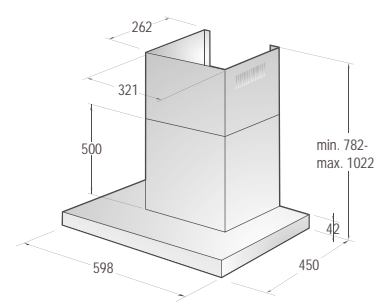

WHT 623 E5X

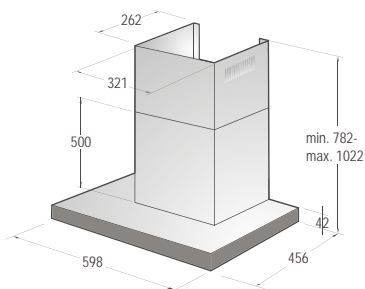

WHT 623 E3XBG

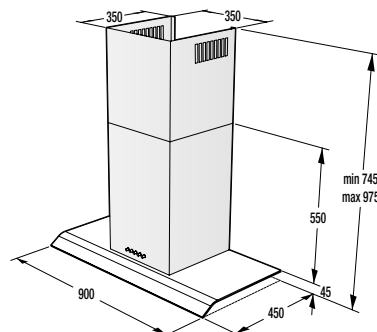

WHGC 933 E16X

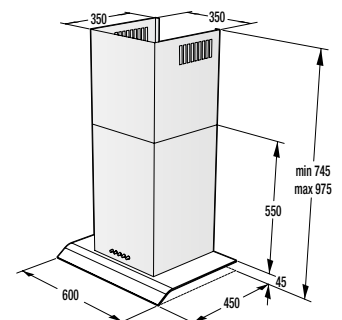

WHGC 633 E16X

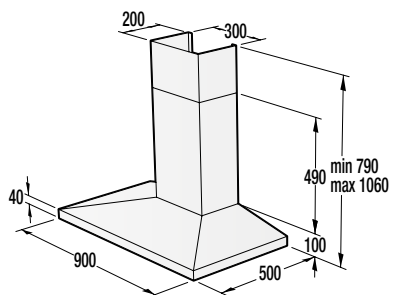

WHC 943 A1XGB

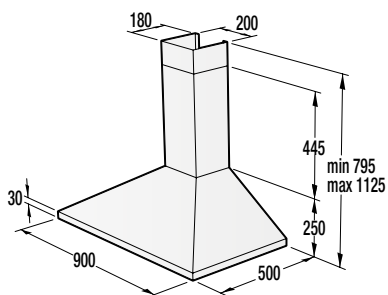

WHC 923 E16X / WHC 923 E14X

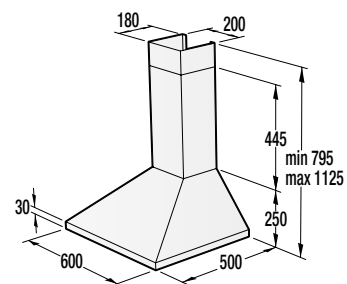

WHC 623 E16X / WHC 623 E14X

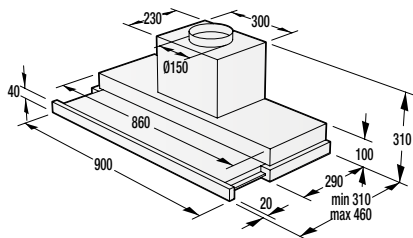

BHP 923 E13X

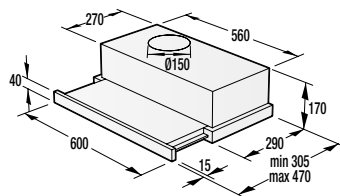

BHP 623 E11X

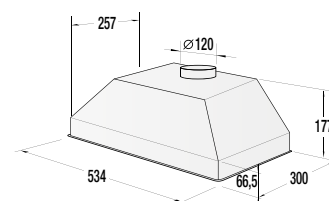

BHI 611 ES

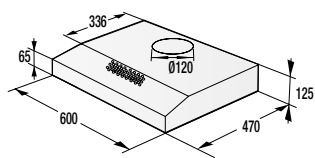

WHU 629 ES/S / WHU 629 EW/S

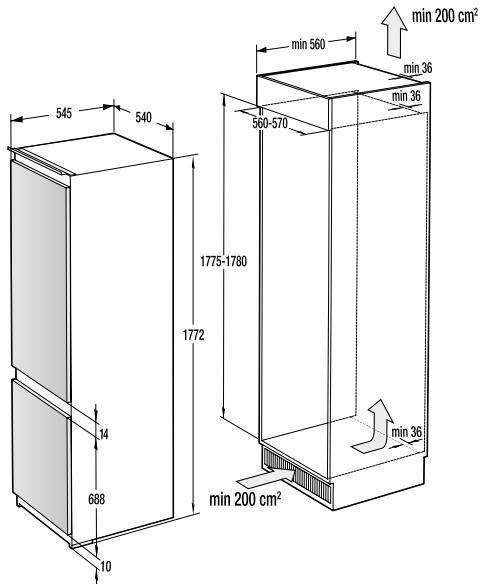

NRKI 2181 A1

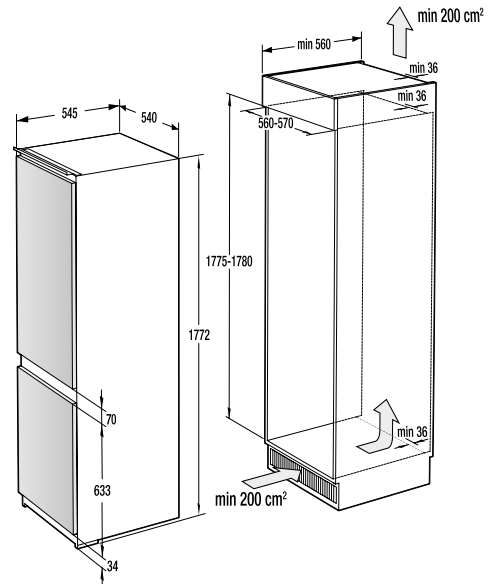

NRKI 4181 E1 / NRKI 4181 P1 / RKI 4181 E3

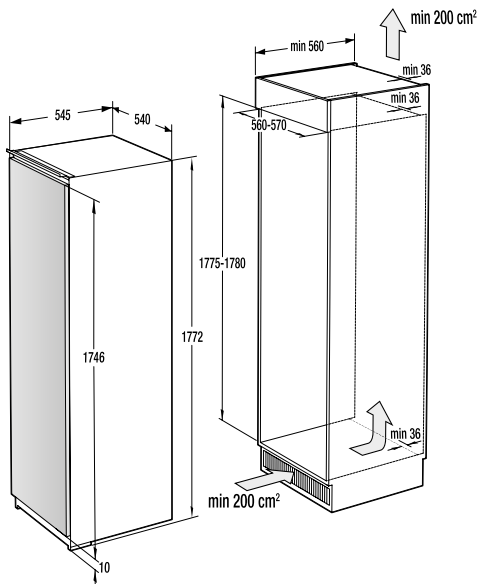

RI 2181 A1 / FNI 5182 A1

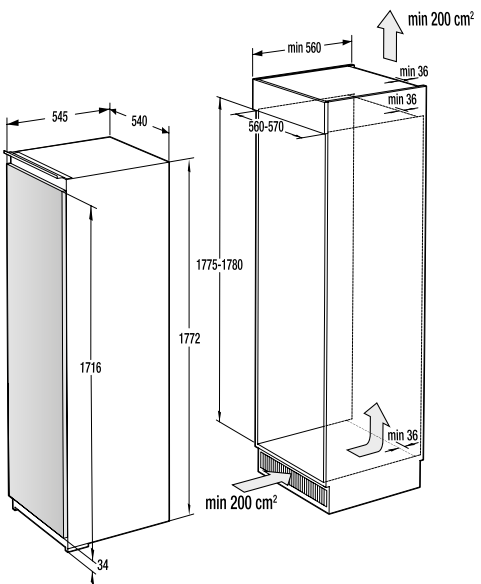

RI 4181 E1 / FNI 4181 E1

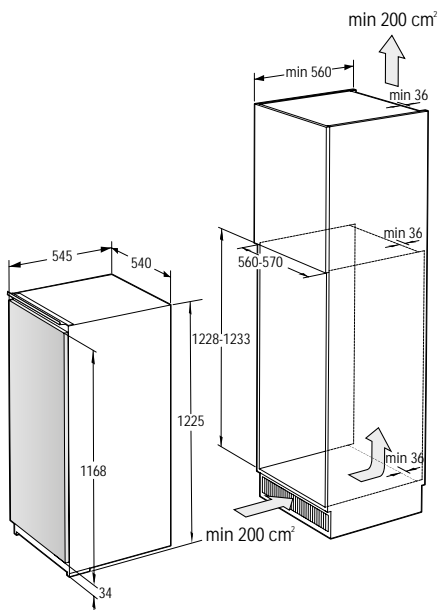

RBI 4121 E1

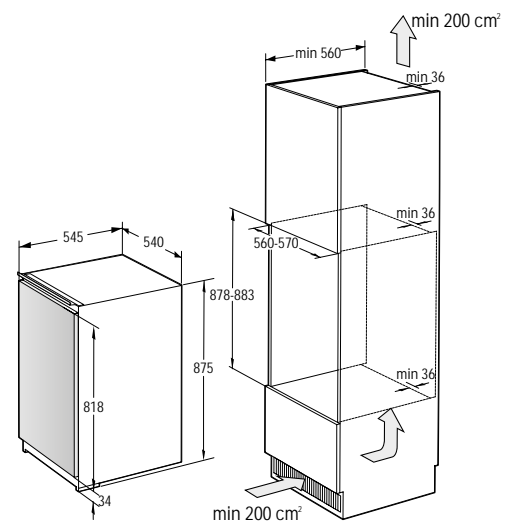

RBI 4091 AW

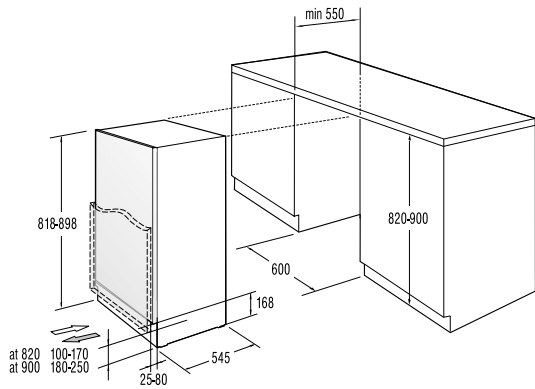

RBIU 6091 AW

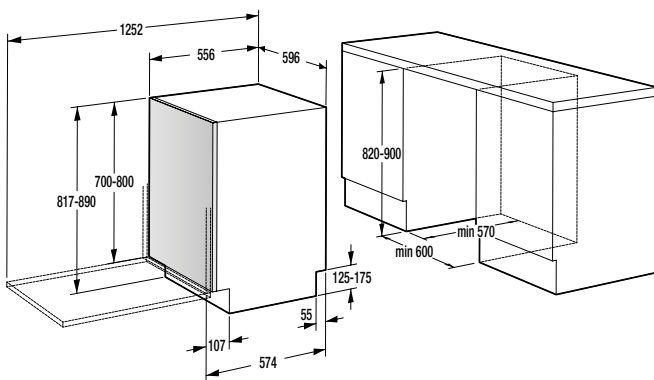

GV 66260

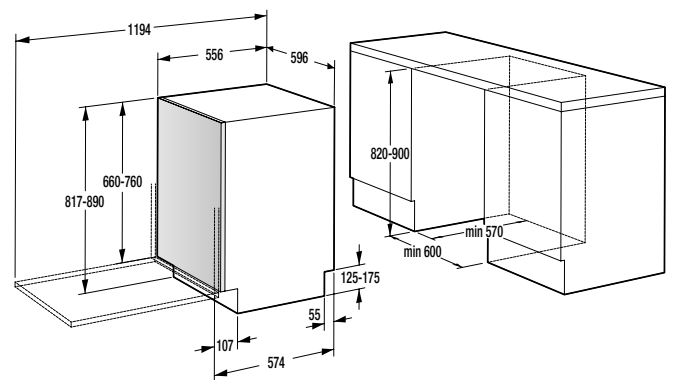

GV 63160

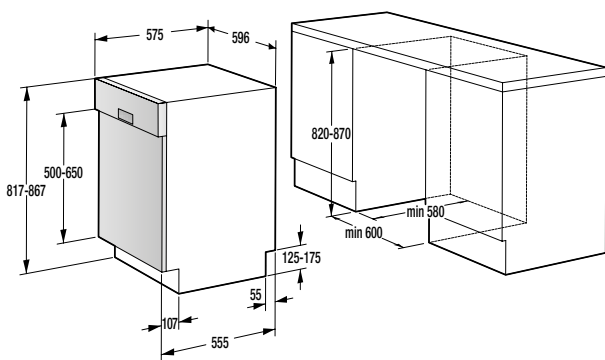

GI 66160 S / GI 64160

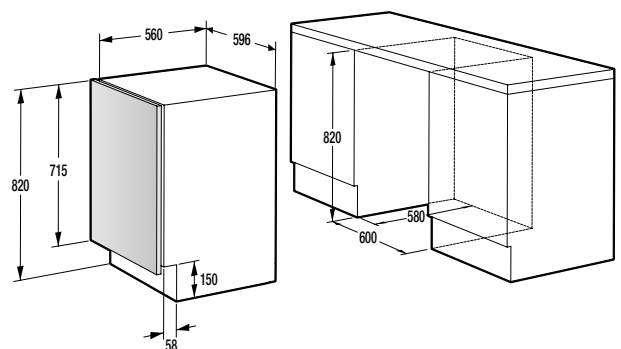

WDI 73121 HK

gorenje

Gorenje Gulf FZE
S3B3SR04, JAFZA (South),
Dubai, UAE
PO Box: 18651
T +971 4 886 08 58
F +971 4 886 09 58
www.gorenje.com
FB: @Gorenje.MEA

www.vosoughishop.com

دفتر مرکزی : مشهد، بین قرنی ۳۱ و ۳۳

تلفن : ۰۵۱ - ۳۷۱۳۳۰۰۰